



STATE OF NEW YORK
OFFICE OF GENERAL SERVICES
DESIGN AND CONSTRUCTION GROUP
THE GOVERNOR NELSON A. ROCKEFELLER
EMPIRE STATE PLAZA
ALBANY, NY 12242



ADDENDUM NO. 5 TO PROJECT NO. 44124

**CONSTRUCTION WORK
REPLACE WINDOWS,
BUILDING NOS. 22 & 23
BEDFORD HILLS CORRECTIONAL FACILITY
247 HARRIS ROAD
BEDFORD HILLS, NY 10507**

January 13, 2012

NOTE: This Addendum forms a part of the Contract Documents. Insert it in the Project Manual. Acknowledge receipt of this Addendum in the space provided on the Bid Form.

1. SECTION 015213 - STATE FIELD OFFICE: Add the accompanying section (pages 015213-1 to 015213-4) to the project manual.
2. Page 011000-2 – Change Paragraph 1.08 E, to Read:

Where shelving interferes with execution of the work in Building No.22, remove shelving and store where directed. Reset shelving when directed. Approximately 20 lf of heavy duty shelving will need to be removed and reset. The shelving is 10 ft. high x 4 ft. deep. The contents of the shelving will be removed and reset by facility personnel. All other furniture and portable equipment which interferes with execution of the Work will be removed and reset by Facility personnel.
3. Page 085663-1 – Article 1.02 A, Add the following paragraph;
 - “2. Optimum Window Mfg. Corp., 28 Canal Street, Ellenville, New York 12428, phone (845) 647-1900, www.optimumwindow.com.”
4. Page 085663-2 – Change paragraph 1.07 A to read:
 - “A. Detention Windows Manufacturer’s Qualifications: The manufacturer of custom steel windows shall be regularly engaged in the production of custom steel windows, shall have furnished custom steel windows for 5 similar projects that have been in operation for not less than 3 years, and shall be subject to the approval of the Director Representative.”
5. Page 085663-6 – Article 2.03, Add the following paragraph;
 - “F. Bonderized and Polyester Powder Coat Finish System:
 1. Bonderizing: After shot blasting; all materials to be bonderized or pretreated by a four stage process as a preparation for receiving paint, as follow
 - a. High pressure wash with degreaser applied at minimum 150 degrees Fahrenheit.

- b. Warm water rinse.
- c. Iron phosphate applied at minimum 130 degrees Fahrenheit.
- d. Warm water rinse with a non-chrome post treatment solution.
- 2. Prime Paint: After bonderizing, a coat of rich thermosetting epoxy prime paint shall be applied and oven baked
 - a. Bake at 325 degrees Fahrenheit.
 - b. Dry film thickness of primer to be a minimum of 1.5 mils.
- 3. Finish Paint: After prime coat, a baked on polyester powder coat finish system shall be applied.
 - a. Bake at 410 degrees Fahrenheit.
 - b. Total dry film thickness to be a minimum of 3.0 mils.”
- 6. Drawing A-200:
 - a. Construction Keyed Notes: Add the following to Note No.5: ...”PAINT LADDER WITH TYPE EAL-3 PAINT.
- 7. Drawing A-504:
 - a. Detail 13: Change note “REINSTALLED METAL ANGLE AT A.C. UNIT, TYP.” To read “PROVIDE GALVANIZED L3x3x1/4 x8” LONGER THAN WIDTH OF MASONRY OPENING. EXPANSION BOLT ANGLE TO EACH SIDE OF MASONRY OPENING WITH 1-3/8”x2 1/2” LG. GALVANIZED EXPANSION BOLT EA. SIDE. COORDINATE HEIGHT WITH REINSTALLED AC UNIT. PAINT ANGLE WITH TYPE EAL-3 PAINT.”
- 8. Addendum Drawing:
 - a. Drawing No. C1.1, titled “OFFICE TRAILER LOCATION PLAN ADDENDUM DRAWING” and dated 1-13-2012 accompanies this Addendum and forms part of the construction documents.

END OF ADDENDUM

James M. Davies, A.I.A.
Director of Design

SECTION 015213**STATE FIELD OFFICE****PART 1 GENERAL****1.01 SECTION INCLUDES**

- A. Provide and maintain a field office comprised of a new custom built mobile or relocatable office unit, new furniture, and new equipment, stair and ramp for the sole use of the Director's Representative and staff. Include temporary services and accessories necessary for use of the items specified.

1.02 SUBMITTALS

- A. Waiver of Submittals: The "Waiver of Certain Submittal Requirements" in Section 013300 does not apply to this Section.
- B. Shop Drawings:
 - 1. Site Plan: Show location of field office where directed. Indicate holding tank, utility services, and connections.
 - 2. Installation Drawings: Show pier type and locations and method of tie down to secure unit from high winds.
- C. Product Data: Catalog sheets, specifications, and installation instructions, for all major items. Submit within 15 days after award of Contract.

1.03 SCHEDULING

- A. Provide units, ready for occupancy by the Director's Representative and staff, within 30 days after shop drawings specified above are approved.

1.04 QUALITY ASSURANCE

- A. Accessibility Requirements: Provide fully accessible units including stairs and ramps that comply with ICC/ANSI A117.1 as referenced by the Building Code of New York State.
- B. Provide units and all related utility connections in accordance with the NYS Uniform Fire Prevention and Building Code.
- C. Provide certification insignia from New York Department of State that certifies trailer unit is code compliant.

PART 2 PRODUCTS**2.01 MOBILE OR RELOCATABLE OFFICE UNITS**

- A. Manufacturers/Companies:
 - 1. ModSpace, 1620 Route 9, Clifton Park, NY 12065-0511, (518) 371-0384, www.modspace.com.

2. Williams Scotsman, Corporate Headquarters, 8211 Town Center Dr., Baltimore, MD 21236, (800) 782-1500, www.willscot.com.
 3. Anchor Modular Buildings, PO Box 100, Medford, NJ 08055, (866) 396-0227, www.anchormodular.com.
- B. Number, Approximate Size and Model:
1. One, 12 x 56 feet, office unit Model GS-1260 by ModSpace (basis of design).
- C. Office Unit Requirements:
1. Ceiling Height: 8'-0" minimum.
 2. Insulation: Exceed code required minimums for insulation. If wood frame construction, exceed the following values, walls > R - 11, floor > R - 19 and roof > R - 19. Provide code requirements and provided insulation values.
 3. Exterior Doors: Minimum 2, minimum 34 inches wide, with key-in-lever locksets.
 4. Windows: Approximately 7 percent of exterior wall area with insect screens
 5. Complete ducted heating, ventilating, and air conditioning system with sufficient capacity to maintain a summer office temperature of 75 degrees F and a winter office temperature of 70 degrees F.
 6. Water Heater: 6 gal minimum.
 7. VCT or sheet vinyl floor finish.
 8. Interior partitions to be wood 2 x 4 framing with ½" vinyl covered gypsum board.
 9. Fluorescent lights in all rooms as required to maintain a minimum of 60-foot candles at desktop level.
 10. Bulletin board (4 feet x 6 feet).
 11. Toilet room with toilet, grab bars, toilet tissue dispenser, lavatory, built-in medicine cabinet, paper towel dispenser and mirror.
 12. Insulated skirting from bottom of units to grade, around entire unit. Skirting is to be 2' x 4' wood framing with 2" rigid insulation type SM and white ventilated vinyl siding to match unit.
 13. Electric energy and fuel for the duration of the Contract.
 14. Pre-wire unit for voice and data (5 connections each) as shown on approved shop drawings.

2.02 FURNITURE

- A. Modular Partition Panels:
1. Manufacturer: Global Industrial (basis of design), 11 Harbor Park Drive, Port Washington, NY.
 2. Provide 60" High Panels and hardware as required to assemble free standing modular partitions as shown on floor plan attached to this section.
 3. Panels to be Fabric upholstered framed on MDF frame (or PVC plastic). 1-3/4" thick, with a honeycomb core covered with tackable liner.
 4. Provide steel connectors as required.
 5. Color: As selected by the Directors Representative from manufacturer's full range.

PART 3 EXECUTION**3.01 INSTALLATION**

- A. Install units where directed. Remove wheels and store them where directed. Block and level unit on piers and secure with tie-downs.
- B. Provide manufacturer's stair with platform at one exterior door and ramp with platform(s) at one exterior entrance.
- C. Provide parking area of Sub-base Course Type 2 as shown on the plans and maintain for the duration of the contract including snow removal.
- D. Provide sanitary sewer lines including excavation and backfill from office unit to existing sewer as shown on the plans.
- E. Provide water service to office unit from on site water main as indicated on the plans. Retain and pay for a plumber to run the lines underground below frost line. Include excavation and backfill.
- F. Provide electric and Cablevision telecommunication service to unit from the adjacent quartermaster building as shown on the plans. Include 10' above grade 4x4 mast for overhead connections. Retain and pay contractor to do the electrical service and connections.
- H. Furnish and install insulated skirt around the bottom of the office unit. Skirt shall fully enclose the open area under the unit.
- I. Assemble and install modular partitions. Anchor to wall and floor.

3.02 MAINTENANCE AND CLEANING

- A. Maintain and clean the office units for the duration of this Contract. Include the following:
 - 1. Daily removal of rubbish.
 - 2. Daily cleaning of toilet room, including the plumbing fixtures. Replenish toilet room supplies as needed.
 - 3. Weekly mopping of floors.
 - 4. Weekly dusting of offices and other rooms.
- B. Maintain approaches free of mud and snow.
- C. Protect water lines from freezing.

3.03 OWNERSHIP

- A. Upon completion of this Project, furnish Bill of Sale and transfer of ownership of all items included in this Section to the State of New York, Office of General Services.

3.04 TRAILER PLAN

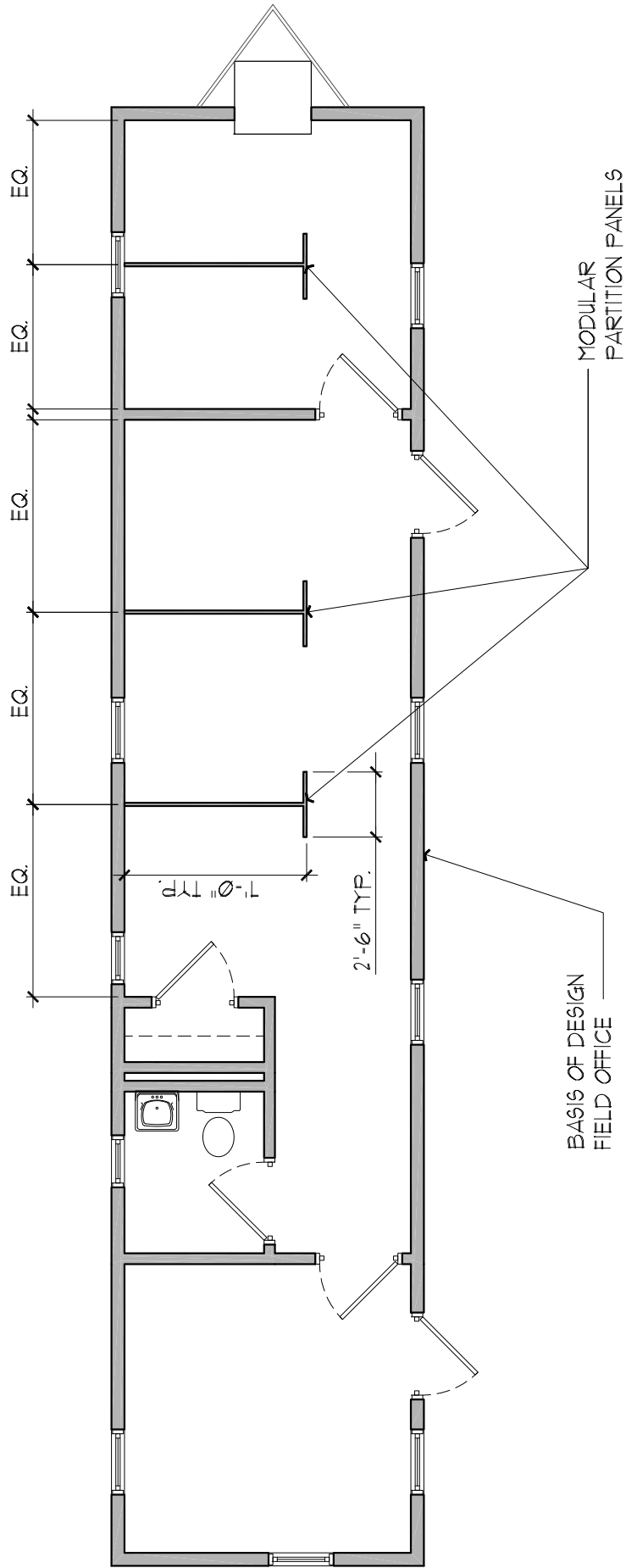

END OF SECTION

 **MODULAR PARTITION PANEL LAYOUT**
SCALE: N.T.S.

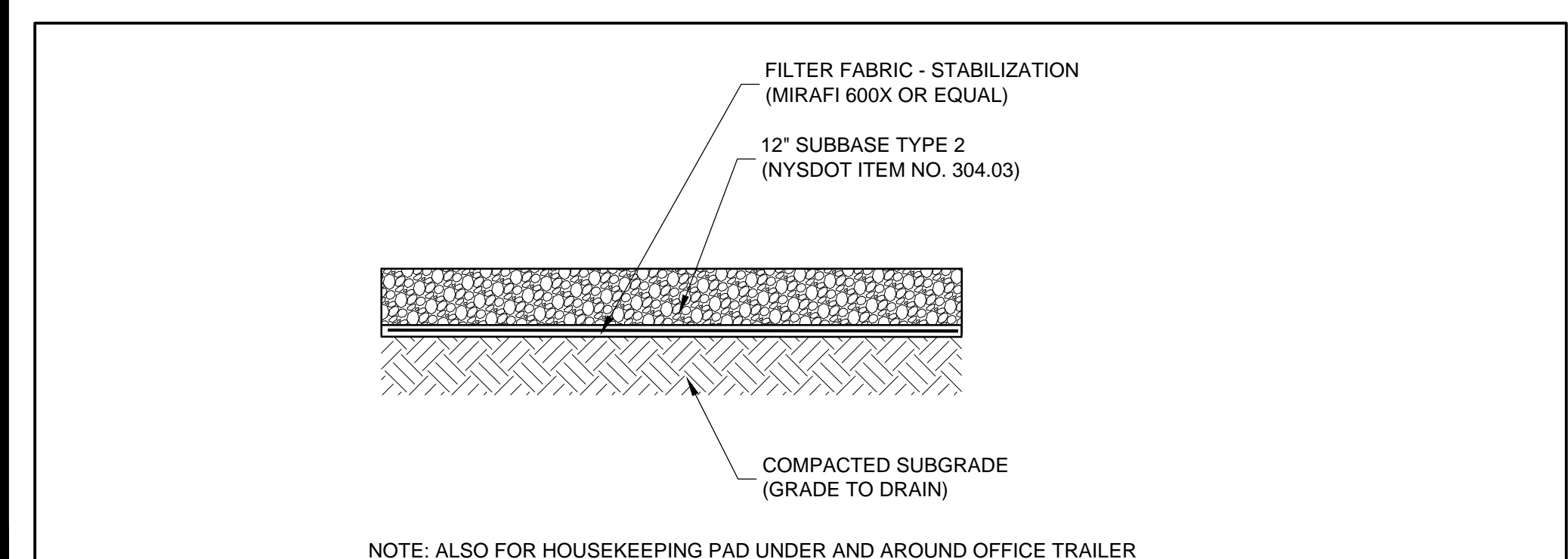
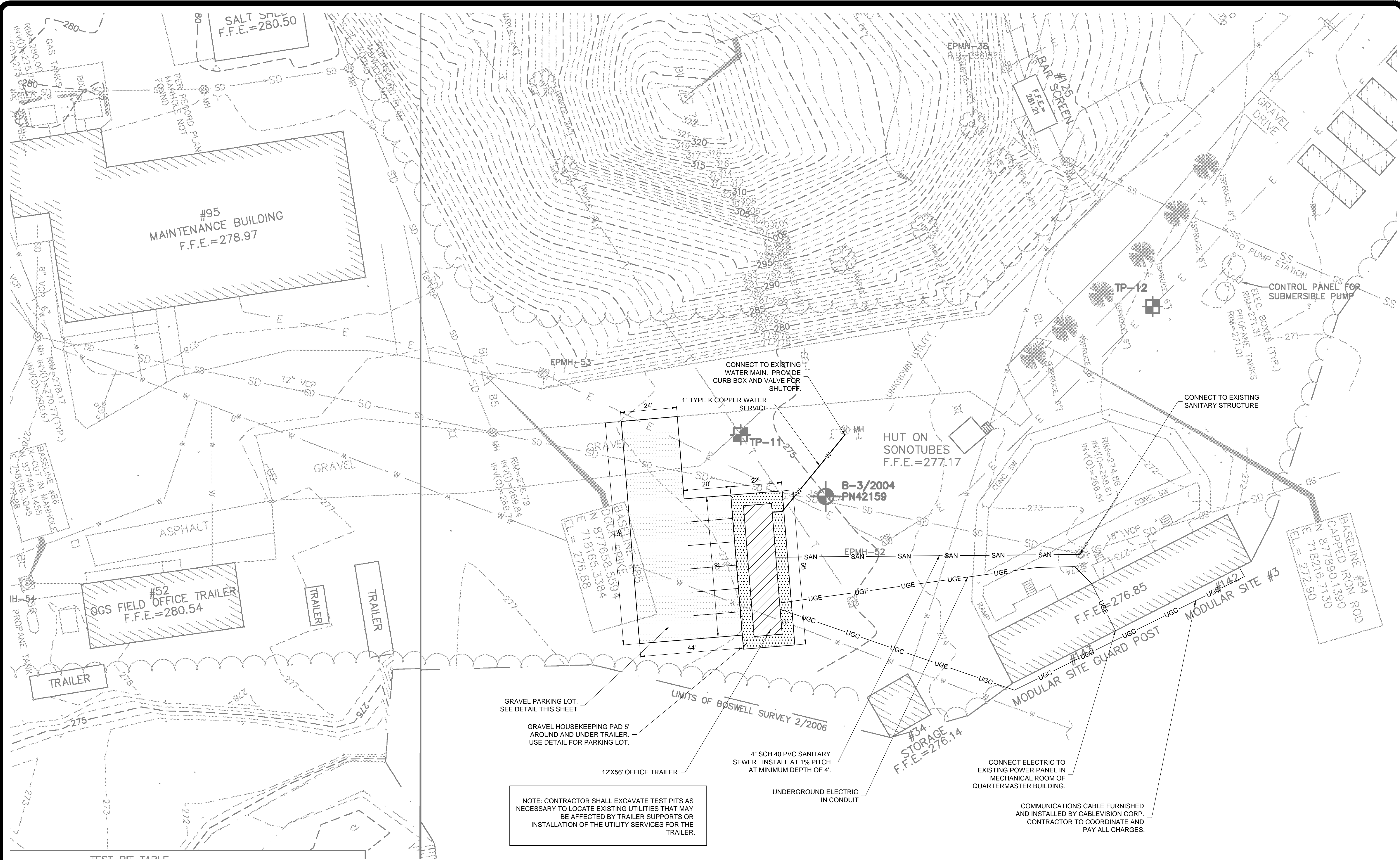

NOTE: CONTRACTOR SHALL EXCAVATE TEST PITS AS NECESSARY TO LOCATE EXISTING UTILITIES THAT MAY BE AFFECTED BY TRAILER SUPPORTS OR INSTALLATION OF THE UTILITY SERVICES FOR THE TRAILER.



6 GRAVEL PARKING LOT SECTION

SCALE N.T.S.



Serving New York
 ANDREW CUOMO
 Governor
 ROANN M. DESTITO
 Commissioner
 JAMES M. DA VIES, A.I.A.
 Deputy Commissioner, Design and Construction



WARNING:
 THE ALTERATION OF THIS MATERIAL IN ANY WAY, UNLESS DONE UNDER THE DIRECTION OF A COMPARABLE PROFESSIONAL, I.E. ARCHITECT FOR AN ARCHITECT, ENGINEER FOR AN ENGINEER, OR LANDSCAPE ARCHITECT FOR A LANDSCAPE ARCHITECT, IS A VIOLATION OF THE NEW YORK STATE EDUCATION LAW AND/OR REGULATIONS AND IS A CLASS "A" MISDEMEANOR.



CONTRACT:

TITLE: REPLACE WINDOWS BUILDING NOS. 22 AND 23

LOCATION: BEDFORD HILLS CORRECTIONAL FACILITY
 247 HARRIS ROAD
 BEDFORD HILLS, NY 10507

CLIENT: DEPARTMENT OF CORRECTIONS AND COMMUNITY SUPERVISION

MARK	DATE	DESCRIPTION
	01/13/2012	ADDENDUM 5
	09/16/2011	BID SUBMISSION
PROJECT NUMBER:	44124 - C	
DESIGNED BY:	THF	
DRAWN BY:	THF	
FIELD CHECK:		
APPROVED:		
SHEET TITLE:	OFFICE TRAILER LOCATION PLAN ADDENDUM DRAWING	
DRAWING NUMBER:	C-1.1	
SHEET	OF	