

**General Specifications  
Liquid Bituminous Materials**

**Award #23428**

## Table of Contents

<b>LOT 1: ASPHALT EMULSIONS</b> .....	<b>5</b>
1.1 Introduction .....	5
1.2 Pricing Information .....	5
1.2.1 General .....	5
1.2.2 Insurance .....	5
1.3 Asphalt Price Adjustments – Asphalt Emulsions .....	6
1.3.1 General .....	6
1.3.2 Asphalt Price Adjustment – Asphalt Emulsions: Example .....	8
1.4 Minimum Order .....	8
1.5 Payment .....	8
1.6 Detailed Specifications – Asphalt Emulsions .....	9
<b>LOT 2: CHIP SEAL</b> .....	<b>10</b>
2.1 Introduction .....	10
2.2 Pricing Information .....	10
2.2.1 General .....	10
2.2.2 Insurance .....	10
2.3 Asphalt Price Adjustments – Chip Seal .....	10
2.3.1 General .....	10
2.3.2 Asphalt Price Adjustment – Chip Seal: Example .....	12
2.4 Payment .....	12
2.5 Payment for Mobilization from Contractor’s Location to Project Location and to Heat, Haul, and Apply Bituminous Material with Contractor’s Equipment .....	13
2.6 Pre-Chip Seal Meeting .....	13
2.7 Supervision .....	13
2.8 Work Hours .....	13
2.9 Construction Details .....	13
2.10 Restoration of Disturbed Areas .....	13
2.11 Damaged or Deficient Areas .....	14
2.12 Damage Claims .....	14
2.13 Work Zone Traffic Control .....	14
2.13.1 Special Note - Temporary Pavement Markings .....	16
2.13.2 Additional Flaggers for Work Zone Traffic Control .....	16
2.13.3 Abrading Existing Pavement Markings with Work Zone Traffic Control by the Contractor .....	16
2.13.4 Special Note: Work Zone Intrusion Initiative .....	17
2.14 Detailed Specifications – Chip Seal .....	17
<b>LOT 3: COLD RECYCLING</b> .....	<b>18</b>
3.1 Introduction .....	18
3.2 Pricing Information .....	18
3.2.1 General .....	18
3.2.2 Insurance .....	18
3.3 Asphalt Price Adjustments – Cold Recycling .....	19
3.3.1 General .....	19
3.3.2 Asphalt Price Adjustment – Cold Recycling: Example .....	20
3.4 Minimum Project Size .....	21
3.5 Delivery Ticket .....	21
3.6 Payment .....	21
3.7 Pre-Recycling Meeting .....	22
3.8 Supervision .....	22
3.9 Work Hours .....	22
3.10 Mix Design .....	23
3.11 Coring by the Contractor for Non NYSDOT Projects .....	23
3.12 Shoulder Milling .....	24
3.13 Restoration of Disturbed Areas .....	24
3.14 Optional Work Zone Traffic Control .....	24

3.14.1	Special Note - Temporary Pavement Markings .....	26
3.14.2	Additional Flaggers for Work Zone Traffic Control .....	26
3.14.3	Work Zone Traffic Intrusion Initiative.....	27
3.15	Detailed Specifications – Cold Recycling Asphalt Concrete .....	28
<b>LOT 4:</b>	<b>HEATER SCARIFICATION.....</b>	<b>30</b>
4.1	Introduction .....	30
4.2	Pricing Information .....	30
4.2.1	General.....	30
4.2.2	Insurance .....	30
4.3	Asphalt Price Adjustments – Heater Scarification .....	30
4.3.1	General.....	30
4.3.2	Asphalt Price Adjustment – Heater Scarification: Example.....	32
4.4	Minimum Project Size.....	32
4.5	Payment.....	32
4.6	Payment for Mobilization from Contractor’s Equipment Storage Facility to Project Location .....	32
4.7	Payment to Heat, Haul, and Apply Recycling Agent from Contractor’s Bituminous Storage Facility to Project Location .....	33
4.8	Pre-Heater Scarification Meeting .....	33
4.9	Supervision.....	33
4.10	Work Hours .....	33
4.11	Mix Design.....	33
4.11.1	Mix Design for NYS Department of Transportation (NYSDOT).....	33
4.11.2	Mix Design for Authorized Users other than NYSDOT .....	33
4.12	Restoration of Disturbed Areas .....	33
4.13	Damaged or Deficient Areas .....	34
4.14	Optional Work Zone Traffic Control.....	34
4.14.1	Special Note - Temporary Pavement Markings .....	36
4.14.2	Additional Flaggers for Work Zone Traffic Control .....	36
4.14.3	Pilot Vehicles with Drivers .....	37
4.14.4	Work Zone Traffic Intrusion Initiative.....	37
4.15	Detailed Specifications – Heater Scarification .....	37
<b>LOT 5:</b>	<b>MICRO-SURFACING AND/OR QUICK SET SLURRY SEAL .....</b>	<b>38</b>
5.1	Introduction .....	38
5.2	Pricing Information .....	38
5.2.1	General.....	38
5.2.2	Insurance .....	39
5.3	Asphalt Price Adjustments – Micro-surfacing and/or Quick Set Slurry Seal.....	40
5.3.1	General.....	40
5.3.2	Asphalt Price Adjustment – Micro-surfacing and/or Quick Set Slurry Seal: Example.....	42
5.4	Delivery Ticket.....	42
5.5	Payment.....	42
5.6	Pre-Micro-surfacing and/or Quick Set Slurry Seal Meeting.....	43
5.7	Supervision.....	43
5.8	Work Hours .....	43
5.9	Construction Details .....	44
5.10	Restoration of Disturbed Areas .....	44
5.11	Damaged or Deficient Areas .....	44
5.12	Optional Work Zone Traffic Control.....	44
5.12.1	Special Note: Temporary Pavement Markings.....	46
5.12.2	Additional Flaggers for Work Zone Traffic Control .....	46
5.12.3	Optional Pilot Vehicles with Drivers .....	46
5.12.4	Optional Additional Construction Signs .....	47
5.12.5	Abrading of Existing Pavement Markings with Work Zone Traffic Control by the Authorized User.....	47
5.12.6	Abrading Existing Pavement Markings with Work Zone Traffic Control by the Contractor .....	47
5.12.7	Special Note: Work Zone Intrusion Initiative .....	48
5.13	Detailed Specifications – Micro-surfacing and/or Quick Set Slurry Seal.....	48

<b>LOT 6: PAVER PLACED SURFACE TREATMENT – CONVENTIONAL AND MODIFIED .....</b>	<b>49</b>
6.1 Introduction .....	49
6.2 Pricing Information .....	49
6.2.1 General .....	49
6.2.2 Insurance .....	50
6.3 Asphalt Price Adjustments – Paver Placed Surface Treatment .....	50
6.3.1 General .....	50
6.3.2 Asphalt Price Adjustment – Paver Placed Surface Treatment: Example .....	52
6.4 Minimum Quantities .....	52
6.5 Delivery Ticket .....	52
6.6 Payment .....	52
6.7 Pre-Conventional or Modified Paver Placed Surface Treatment Meeting .....	53
6.8 Supervision .....	53
6.9 Work Hours .....	53
6.10 Construction Details .....	54
6.11 Saturday and Sunday Work .....	54
6.12 Damaged or Deficient Areas .....	54
6.13 Optional Overlay Splices with Work Zone Traffic Control by the Authorized User .....	54
6.14 Optional Overlay Splices with Work Zone Traffic Control by the Contractor .....	54
6.15 Optional Work Zone Traffic Control .....	54
6.15.1 Special Note: Temporary Pavement Markings .....	57
6.15.2 Additional Flaggers for Work Zone Traffic Control .....	57
6.15.3 Optional Pilot Vehicle with Drivers .....	58
6.15.4 Optional Additional Construction Signs .....	58
6.15.5 Abrading Existing Pavement Markings with Work Zone Traffic Control by the Authorized User .....	58
6.15.6 Abrading Existing Pavement Markings with Work Zone Traffic Control by the Contractor .....	58
6.15.7 Special Note: Work Zone Intrusion Initiative .....	59
6.16 Detailed Specifications – Paver Placed Surface Treatment (Conventional and Modified) .....	59
<b>LOT 7: JOINT AND CRACK FILLER/SEALER, AND MASTIC REPAIR MATERIAL .....</b>	<b>60</b>
7.1 Introduction .....	60
7.2 Pricing Information .....	60
7.2.1 General .....	60
7.2.2 Insurance .....	61
7.3 Asphalt Price Adjustments – Joint and Crack Filler/Sealer and Mastic Repair Material .....	62
7.3.1 General .....	62
7.3.2 Asphalt Price Adjustment – Joint and Crack Filler/Sealer: Example .....	63
7.4 Minimum Order .....	64
7.5 Delivery Ticket .....	64
7.6 Payment .....	64
7.7 Work Hours .....	64
7.8 Optional Work Zone Traffic Control .....	64
7.8.1 Additional Flaggers for Work Zone Traffic Control .....	65
7.8.2 Optional Pilot Vehicles with Drivers .....	65
7.8.3 Special Note: Work Zone Intrusion Initiative .....	66
7.9 Detailed Specifications – Joint and Crack Filler/Sealer and Mastics .....	66

## LOT 1: ASPHALT EMULSIONS

### 1.1 Introduction

Asphalt emulsions are liquid bituminous materials (asphalt cement, water and an emulsifying agent) which are applied either separately or with crushed stone to seal the surface of highway pavements. Asphalt emulsions are also applied as tack coats in conjunction with highway pavement resurfacing with bituminous concrete materials.

### 1.2 Pricing Information

#### 1.2.1 General

Price bid with the exception of F.O.B. Storage Facility shown herein must include material cost and cost to furnish, heat, haul, deliver and apply with Contractor's equipment.

The price (mile and gallon range) for a specific job will be calculated at the same rate. This rate will be determined by finding the one category that applies to the total miles and gallons per job. For example, a job that is 11 miles from the plant will be calculated at the same rate per gallon for each mile (from 1 to 11) that is indicated in the 11-25 mile column herein, rather than on a cumulative basis. Similarly, a job that is 16 miles from the plant and required 4,000 gallons over a two-day period would be calculated using the 11-25 mile row and the 1,001-3,000 gallon range since it would be presumed that equal quantities would be applied each day.

**Price for optional Self-propelled Aggregate Spreader with Operator** is net per day per spreader with operator and includes mobilization.

**Price quoted for optional 10-ton Pneumatic Tire Roller with Operator** is net per day per 10-ton pneumatic tire roller with operator and includes mobilization.

**Excess Time Charge for All Items except Diluted Tack Coat (Material Designation 407.0102), Straight Tack Coat (Material Designation 407.0103) and Non-Tracking Tack Coat (Material Designation 407.01040009):**

This is the charge for each 15-minute period or portion thereof for a delay attributable to the Authorized User after scheduled delivery time. Excess time charges do not apply while Contractor is unloading and/or applying material. They only apply when Contractor is delayed by the Authorized User.

**Hourly Charge for Diluted Tack Coat (Material Designation 407.0102), Straight Tack Coat (Material Designation 407.0103) and Non-Tracking Tack Coat (Material Designation 407.01040009):**

This is the charge per hour that an Asphalt Emulsion distributor truck is on the project commencing at the scheduled start time indicated by the Authorized User and ending when the Authorized User has indicated to the distributor truck operator that no more Tack Coat is needed for the day. No deduction of time spent applying tack coat shall be made from the payment of the hourly charge. No adjustment shall be allowed for work hours longer than the standard workday. Excess Time Charge does not apply to Diluted Tack Coat (Material Designation 407.0102), Straight Tack Coat (Material Designation 407.0103) and Non-Tracking Tack Coat (Material Designation 407.01040009):.

It is inherent in the application of Tack Coat that the distributor applies tack coat for a very short period of time and then must wait until the emulsion breaks and the Asphalt Mix is placed over the tack coat before Tack Coat may be applied at another location on the project. To fairly compensate Contractors for expenses incurred during long periods of inactivity where Tack Coat distributor trucks and operators must be in stand-by mode on the project, an hourly charge for time actually spent on the project after the scheduled starting time has been introduced. This hourly charge is for time spent on the project, both applying tack coat and waiting to apply tack coat.

#### 1.2.2 Insurance

Please refer to Section 6.19 - Insurance of the Invitation for Bids for information about insurance.

**LOT 1: ASPHALT EMULSIONS (Cont'd)**

**1.3 Asphalt Price Adjustments – Asphalt Emulsions**

**1.3.1 General**

- a. Asphalt price adjustments allowed will be based on the November 1, 2025, average of the F.O.B. terminal price per ton of unmodified PG 64S-22 binder without anti-stripping agent (base average F.O.B. terminal price). The new monthly average terminal price will be determined by the New York State Department of Transportation based on prices of pre-approved primary sources of performance graded binder in accordance with the New York State Department of Transportation Standard Specification.

**The November 1, 2025 average is \$638.000**

**NOTE:** The same grade of asphalt cement used in establishing the base average F.O.B. terminal price shall be used in establishing the new average F.O.B. terminal price.

In the event that one or more of the New York State Department of Transportation pre-approved sources discontinue posting a price for asphalt cement, the base average F.O.B. terminal **price shall not be recalculated.**

- b. The new average F.O.B. terminal price will be determined based on the above F.O.B. terminal prices posted each month during the contract period. However, asphalt price adjustments, in accordance with the formula below, will be effective for deliveries made on and after the first of the month following the adjustment date.
- c. The unit prices of bituminous materials purchased from any award based on this specification will be subject to adjustment based on the following formula:

Price Adjustment (per gallon)	=	<table style="width: 100%; border-collapse: collapse;"> <tr> <td style="width: 50%; border-bottom: 1px solid black;">New Monthly Average FOB Terminal Price</td> <td style="width: 5%; text-align: center;">-</td> <td style="width: 45%; border-bottom: 1px solid black;">Base Average Terminal Price</td> </tr> <tr> <td colspan="3" style="border-top: 1px solid black; padding-top: 5px;">235</td> </tr> </table>	New Monthly Average FOB Terminal Price	-	Base Average Terminal Price	235			X	Total Allowable Petroleum %
New Monthly Average FOB Terminal Price	-	Base Average Terminal Price								
235										

Positive Price Adjustment number shall be added to original per gallon Bid Price.

Negative Price Adjustment number shall be subtracted from original per gallon Bid Price.

**New Monthly Average F.O.B. Terminal Price**

The average F.O.B. terminal price for unmodified PG 64S-22 binder without anti-stripping agent is as determined by the New York State Department of Transportation per New York State Department of Transportation Standard Specification.

**Base Average F.O.B. Terminal Price**

The average F.O.B. terminal price of unmodified PG 64S-22 binder without anti-stripping agent is as determined by the New York State Department of Transportation as of November 1, 2025.

LOT 1: ASPHALT EMULSIONS (Cont'd)

**Total Allowable Petroleum**

The percentage of total allowable petroleum for each item is as follows:

Material Designation	Grade	Asphalt %	Petroleum Allowance %	Total Allowable Petroleum %
702-0700	18-60	100.0	0.2	100.2%
702-3001	RS-1	55.0	1.7	56.7%
702-3002	RS-1h	55.0	1.7	56.7%
702-3101	RS-2	63.0	2.7	65.7%
702-3102	HFRS-2	63.0	2.7	65.7%
702-3201	MS-2	65.0	8.2	73.2%
702-3301	HFMS-2	65.0	8.2	73.2%
702-3401	HFMS-2h	65.0	2.7	67.7%
702-3402	HFMS-2s	65.0	8.2	73.2%
702-3501	SS-1	57.0	0.2	57.2%
702-3601	SS-1h	57.0	0.2	57.2%
702-3101P	RS-2p	63.0	2.7	65.7%
702-3102P	HFRS-2p	63.0	2.7	65.7%
702-4001	CRS-1	60.0	2.7	62.7%
702-4002	CRS-1h	60.0	2.7	62.7%
702-4101	CRS-2	65.0	2.7	67.7%
702-4201	CMS-2	65.0	10.2	75.2%
702-4301	CMS-2h	65.0	10.2	75.2%
702-4401	CSS-1	57.0	0.2	57.2%
702-4501	CSS-1h	57.0	0.2	57.2%
702-4601	CQS-1h	62.0	0.2	62.2%
702-4001P	CRS-1p	60.0	2.7	62.7%
702-4101P	CRS-2p	65.0	2.7	67.7%
702-4601P	CQS-1p	62.0	0.2	62.2%
407.0102	Diluted Tack Coat	40.0	0.2	40.2%
407.01040009	Non-Tracking Tack Coat	50.0	0.2	50.2%

Note: For Material Designation 407.0103 Straight Tack Coat, use Total Allowable Petroleum % for appropriate emulsion grade.

Asphalt Price Adjustments will not be allowed for materials which do not have an asphalt cement base.

- d. Work performed after the expiration of the contract, where no extension has been granted, resultant from purchase orders placed prior to expiration of the contract will be based on the new average for the month in which the work is done applying the same base established for that contract.

Asphalt Price Adjustments for any contracts that are extended will be based on the new average for the month in which the work is done applying the same base established for that contract.

**LOT 1: ASPHALT EMULSIONS (Cont'd)**

- e. Asphalt Price Adjustments allowed by this contract shall be calculated and applied to the original prices. There will not be Asphalt Price Adjustments unless the change amounts to more than \$0.010 per gallon from the original price. In these instances, prices will revert back to the original prices.
- f. All Asphalt Price Adjustments will be computed to three decimal places.
- g. Should these provisions result in a price structure which becomes unworkable, detrimental or injurious to the State or in prices which are not truly reflective of market conditions or which are deemed by the Commissioner to be unreasonable or excessive, and no adjustment in price is mutually agreeable, the Commissioner reserves the sole right upon ten days written notice mailed to the Contractor to terminate any contract resulting from this bid opening.
- h. All Asphalt Price Adjustments shall be published by the State and issued to all contract holders whose responsibility will be to attach the appropriate State notification (based on when the work was performed) to the payment invoice submitted to the Authorized User.

**1.3.2 Asphalt Price Adjustment – Asphalt Emulsions: Example**

This example is for illustration purposes only. Actual Base Average Price, etc., may vary:

Material Designation 702-3101

Base Average Price = \$638.000

New Average Price = \$648.000

% Total Allowable Petroleum = 65.7%

Price Adjustment (per gallon)	=	$\frac{(648.000 - 638.000)}{235}$	X	0.657
----------------------------------	---	-----------------------------------	---	-------

Price Adjustment (per gallon)	=	+\$0.028 per gallon
----------------------------------	---	---------------------

Positive Price Adjustment number shall be added to original per gallon Bid Price.

Negative Price Adjustment number shall be subtracted from original per gallon Bid Price.

**1.4 Minimum Order**

The absolute minimum order is 500 gallons for each Material Designation unless agreed by the Contractor.

Note: In a case where a project requires several days to be completed, this minimum order of 500 gallons doesn't apply to the last day of work needed to complete the project.

**1.5 Payment**

Payment shall be made at contract price per gallon for the actual quantities of liquid bituminous material furnished to and verified by the Authorized User. This determination as to quantities involved in any contract shall be accepted as final and binding upon the Contractor. A delivery slip stating quantities shall accompany each shipment. An invoice shall be sent promptly by the Contractor to the Engineer of the region or to the Authorized User Representative placing the order. Measurement shall be based on the volume of the liquid bituminous material at a temperature of 60°F. All invoices shall show an allowance for temperature above 60°F. The temperature - volume correction to obtain the correct volume at 60°F shall be 0.00025 gallons per °F for all asphalt emulsions. The method to be used for volume corrections for other petroleum products shall be the method and coefficients of expansion given in the "Standard Petroleum Tables, A.S.T.M. D1250." The price per unit for other than "Specific Projects" arrived at (mutually estimated) by the Contractor and the Authorized User on the Quick Quote Worksheet/Price Calculation Worksheet or the price per unit resultant from the actual average daily production, whichever is less, shall be the price per unit paid to the Contractor. No additional payment shall be due to the Contractor for production rates that are not equal to the rate upon which the Quick Quote/Price Calculation Worksheet was based.

---

LOT 1: ASPHALT EMULSIONS (Cont'd)

**1.6 Detailed Specifications – Asphalt Emulsions**

All Liquid Bituminous Materials furnished and/or applied, shall be in accordance with Specifications for Bituminous Materials in book entitled New York State Department of Transportation, Standard Specifications, most current version, and all current addenda.

## LOT 2: CHIP SEAL

### 2.1 Introduction

Conventional chip seal is a pavement preventive maintenance treatment which consists of single-sized stone embedded in a liquid bituminous material. The liquid bituminous material seals cracks in the existing pavement and the stone provides a high-friction wearing surface.

### 2.2 Pricing Information

#### 2.2.1 General

Price quoted shall be F.O.B. the Contractor's location per square yard for chip seal. Price quoted for cover sand shall be in place at the project location per square yard for cover sand. Price quoted shall be F.O.B. the Contractor's location per gallon for the liquid bituminous material (used for chip seal and fog sealing). The price bid per square yard for the chip seal and for cover sand shall include the cost of work zone traffic control.

Price quoted for additional flaggers (if required) shall be net per day (to the nearest quarter day) for additional flaggers. Price quoted for optional pickup sweeper(s) (if required) shall be net per day (to the nearest quarter day) for optional pickup sweeper(s) with operator(s). Price quoted for abrading existing pavement markings with work zone traffic control by the Contractor (if required) shall be net per linear foot at 4-inches wide of pavement markings to be abraded. This price shall include all costs for pavement marking abrading including all labor, materials, and equipment necessary to abrade the pavement markings and to properly control traffic.

The Contractor is to furnish all necessary labor and equipment to complete the work under this contract including work zone traffic control. Permanent pavement striping will be the responsibility of the Authorized User upon completion of the chip seal after the Contractor has vacated the project site.

#### **Price quoted for Mobilization from Contractor's Location to Project Location and to Heat, Haul and Apply Bituminous Material with Contractor's Equipment:**

Price quoted for mobilization from Contractor's location to project location shall be net per square yard of accepted chip seal in place performed at the locations indicated by the State's Resident Engineer or Authorized User Representative. Price quoted for heating, hauling, and applying bituminous material from Contractor's location to project location shall be net per gallon of bituminous material incorporated in the completed chip seal in place.

#### 2.2.2 Insurance

Please refer to Section 6.19 - Insurance of the Invitation for Bids for information about insurance.

### 2.3 Asphalt Price Adjustments – Chip Seal

#### 2.3.1 General

- a. Asphalt price adjustments allowed will be based on the November 1, 2025 average of the F.O.B. terminal price per ton of unmodified PG 64S-22 binder without anti-stripping agent (base average F.O.B. terminal price). The new monthly average terminal price will be determined by the New York State Department of Transportation based on prices of pre-approved primary sources of performance graded binder in accordance with the New York State Department of Transportation Standard Specification.

#### **The November 1, 2025 average is \$638.000**

**NOTE:** The same grade of asphalt cement used in establishing the base average F.O.B. terminal price shall be used in establishing the new average F.O.B. terminal price.

In the event that one or more of the New York State Department of Transportation pre-approved sources discontinue posting a price for asphalt cement, the base average F.O.B. terminal **price shall not be recalculated.**

- b. The new average F.O.B. terminal price will be determined based on the above F.O.B. terminal prices posted each month during the contract period. However, asphalt price adjustments, in accordance with the formula below, will be effective for deliveries made on and after the first of the month following the adjustment date.

**LOT 2: CHIP SEAL (Cont'd)**

- c. The unit prices of bituminous materials purchased from any award based on this specification will be subject to adjustment based on the following formula:

$$\begin{array}{|c|} \hline \text{Price} \\ \text{Adjustment} \\ \text{(per gallon)} \\ \hline \end{array} = \frac{\begin{array}{|c|} \hline \text{New Monthly Average} \\ \text{FOB Terminal Price} \\ \hline \end{array} - \frac{\begin{array}{|c|} \hline \text{Base Average} \\ \text{Terminal Price} \\ \hline \end{array}}{235} \times \begin{array}{|c|} \hline \text{Total} \\ \text{Allowable} \\ \text{Petroleum \%} \\ \hline \end{array}$$

Positive Price Adjustment number shall be added to original per gallon Bid Price.  
Negative Price Adjustment number shall be subtracted from original per gallon Bid Price.

**New Monthly Average F.O.B. Terminal Price**

The average F.O.B. terminal price for unmodified PG 64S-22 binder without anti-stripping agent is as determined by the New York State Department of Transportation per New York State Department of Transportation Standard Specification.

**Base Average F.O.B. Terminal Price**

The average F.O.B. terminal price of unmodified PG 64S-22 binder without anti-stripping agent is as determined by the New York State Department of Transportation as of November 1, 2025.

**Total Allowable Petroleum**

The percentage of total allowable petroleum for each item is as follows:

Material Designation	Grade	Asphalt %	Petroleum Allowance %	Total Allowable Petroleum %
702-0700	18-60	100.0	0.2	100.2%
702-3001	RS-1	55.0	1.7	56.7%
702-3002	RS-1h	55.0	1.7	56.7%
702-3101	RS-2	63.0	2.7	65.7%
702-3102	HFRS-2	63.0	2.7	65.7%
702-3201	MS-2	65.0	8.2	73.2%
702-3301	HFMS-2	65.0	8.2	73.2%
702-3401	HFMS-2h	65.0	2.7	67.7%
702-3402	HFMS-2s	65.0	8.2	73.2%
702-3501	SS-1	57.0	0.2	57.2%
702-3601	SS-1h	57.0	0.2	57.2%
702-3101P	RS-2p	63.0	2.7	65.7%
702-3102P	HFRS-2p	63.0	2.7	65.7%
702-3301P	HFMS-2p	65.0	8.2	73.2%
702-4001	CRS-1	60.0	2.7	62.7%
702-4002	CRS-1h	60.0	2.7	62.7%
702-4101	CRS-2	65.0	2.7	67.7%
702-4201	CMS-2	65.0	10.2	75.2%
702-4301	CMS-2h	65.0	10.2	75.2%
702-4401	CSS-1	57.0	0.2	57.2%
702-4501	CSS-1h	57.0	0.2	57.2%
702-4601	CQS-1h	62.0	0.2	62.2%
702-4001P	CRS-1p	60.0	2.7	62.7%
702-4101P	CRS-2p	65.0	2.7	67.7%
702-4601P	CQS-1p	62.0	0.2	62.2%
407.0102	Diluted Tack Coat	40.0	0.2	40.2%

Note: For Material Designation 407.0103 Straight Tack Coat, use Total Allowable Petroleum % for appropriate emulsion grade.

**LOT 2: CHIP SEAL (Cont'd)**

Asphalt Price Adjustments will not be allowed for materials which do not have an asphalt cement base.

- d. Work performed after the expiration of the contract, where no extension has been granted, resultant from purchase orders placed prior to expiration of the contract will be based on the new average for the month in which the work is done applying the same base established for that contract.

Asphalt Price Adjustments for any contracts that are extended will be based on the new average for the month in which the work is done applying the same base established for that contract.

- e. Asphalt Price Adjustments allowed by this contract shall be calculated and applied to the original prices. There will not be Asphalt Price Adjustments unless the change amounts to more than \$0.010 per gallon from the original price. In these instances, prices will revert back to the original prices.
- f. All Asphalt Price Adjustments will be computed to three decimal places.
- g. Should these provisions result in a price structure which becomes unworkable, detrimental or injurious to the State or in prices which are not truly reflective of market conditions or which are deemed by the Commissioner to be unreasonable or excessive, and no adjustment in price is mutually agreeable, the Commissioner reserves the sole right upon ten days written notice mailed to the Contractor to terminate any contract resulting from this bid opening.
- h. All Asphalt Price Adjustments shall be published by the State and issued to all contract holders whose responsibility will be to attach the appropriate State notification (based on when the work was performed) to the payment invoice submitted to the Authorized User.

**2.3.2 Asphalt Price Adjustment – Chip Seal: Example**

This example is for illustration purposes only. Actual Base Average Price, etc., may vary.

Material Designation 702-3101P

Base Average Price = \$638.000

New Average Price = \$648.000

% Total Allowable Petroleum = 65.7%

$$\boxed{\begin{array}{c} \text{Price} \\ \text{Adjustment} \\ \text{(per gallon)} \end{array}} = \boxed{\frac{(648.000 - 638.000)}{235}} \times \boxed{0.657}$$

$$\boxed{\begin{array}{c} \text{Price} \\ \text{Adjustment} \\ \text{(per gallon)} \end{array}} = \boxed{+\$0.028 \text{ per gallon}}$$

Positive Price Adjustment number shall be added to original per gallon Bid Price.

Negative Price Adjustment number shall be subtracted from original per gallon Bid Price.

**2.4 Payment**

Payment for chip seal in place shall be made at the contract price per unit bid for the actual number of square yards of chip seal in place including work zone traffic control, the actual number of square yards of cover sand in place (if used) at the project location including work zone traffic control, the actual number of gallons of asphalt emulsion for the chip seal and the fog seal (if used) at 60°F verified by the Authorized User and used in the accepted portion of the work. Payment for additional flaggers (if required) will be made based on the number of days (computed to the nearest quarter day) that additional flaggers are utilized as directed by the Engineer or the Authorized User Representative. Payment for optional pickup sweepers (if required) will be made based on the number of days (computed to the nearest quarter day) that optional pickup sweepers are utilized as directed by the Engineer or the Authorized User Representative. Payment for abrading existing pavement markings with work zone traffic control by Contractor (if required) will be made based on the number of linear feet at 4-inches wide of pavement markings actually abraded as directed by the Engineer or the Authorized User Representative. The determination as to quantities involved in any contract shall be accepted as final and binding upon the Contractor.

## LOT 2: CHIP SEAL (Cont'd)

A delivery slip stating quantities of liquid bituminous material shall accompany each shipment. An invoice listing the quantities of chip seal and cover sand in place (if used) and liquid bituminous material used for the chip seal and the fog seal (if used) shall be sent promptly by the Contractor to the State's Resident Engineer or to the Authorized User Representative placing the order. Measurement shall be based on the volume of the liquid bituminous material at a temperature of 60°F. The temperature/volume correction to obtain the correct volume at 60°F shall be 0.00025 per degree F for all asphalt emulsions.

### 2.5 Payment for Mobilization from Contractor's Location to Project Location and to Heat, Haul, and Apply Bituminous Material with Contractor's Equipment

Payment for mobilization from Contractor's location to project location shall be made based on the actual number of accepted square yards of chip seal in place at the locations indicated by the State's Resident Engineer or Authorized User Representative at the contract price for mobilization from Contractor's location to project location per square yard of chip seal for the appropriate distance and quantity range.

Payment for heating, hauling, and applying bituminous material from Contractor's location to project location shall be made for the actual number of gallons of asphalt emulsion at 60°F at the appropriate price bid for the actual distance to the project verified by the Authorized User and used in the accepted portion of the work.

### 2.6 Pre-Chip Seal Meeting

The Contractor shall schedule a Pre-Chip Seal Meeting with the Authorized User at least two weeks prior to the start of work under this contract. Project Level supervisors for both the Authorized User and the Contractor will be present at this meeting. At this meeting the Contractor shall present their proposed chip seal schedule, mix design, numbers and type of equipment, and chip seal procedure and Work Zone Traffic Control Plan to the Authorized User for approval. The mix design must clearly show the quantity in gallons per square yard of fog seal (if used), the quantity in pounds per square yard of cover sand (if used), the quantity in gallons and the type of liquid bituminous material per square yard, the quantity in pounds per square yard of aggregate, percent of polymer used to modify the asphalt emulsion, and the design curing time. All the component materials used in the mix design shall be representative of the materials proposed by the Contractor to be used on the project. Adjustments may be required during construction based on field conditions and with the approval of the Authorized User. The Contractor shall also furnish the Authorized User copies of the calibrations of the liquid bituminous material distributor and the aggregate spreader at this time. The Contractor shall indicate the aggregate source. At least one week prior to the start of work under this contract, the Contractor shall coordinate the details of the chip seal with the Authorized User Representative.

### 2.7 Supervision

The Contractor is solely responsible for the control and application of materials and other related operations. The Authorized User shall designate a chip seal supervisor who will monitor the Contractor's operations. All orders pertaining to work zone traffic control from the chip seal supervisor to the Contractor shall be binding on the Contractor. The following portions of Section 105 - CONTROL OF WORK of the Standard Specifications shall apply to these projects: 105-01 ENGINEER'S AUTHORITY, 105-05 CONTRACTOR RESPONSIBILITY, 105-06 COOPERATION WITH UTILITIES AND OTHER CONTRACTORS.

### 2.8 Work Hours

Work will not be permitted on Sundays and Holidays. If the Contractor desires to work overtime on other days, dispensation from the NYS Labor Department must be obtained using Department of Labor Form PW-30.

### 2.9 Construction Details

The construction details shall comply with the requirements specified in the enclosed Attachment 11 - *Detailed Specifications – Liquid Bituminous Materials*. The Contractor shall inform the chip seal Supervisor of significant deviations from the specifications.

### 2.10 Restoration of Disturbed Areas

During the course of the work the Contractor shall take reasonable care not to disturb areas outside the existing pavement. Any areas disturbed by the Contractor shall be returned to their original condition at no expense to the owner. Any and all debris generated as part of the work shall be removed by the Contractor upon completion of the project.

## LOT 2: CHIP SEAL (Cont'd)

### 2.11 Damaged or Deficient Areas

Prior to acceptance and payment for the chip seal by the Authorized User, any chip seal that ravels, delaminates, fails to properly cure, or is in any way defective shall be redone to the satisfaction of the State's or Authorized User Representative at the Contractor's expense. "After acceptance, the terms and conditions of the section of this IFB, Attachment 11 - *Detailed Specifications – Liquid Bituminous Materials -CHIP SEAL, BONDING REQUIREMENTS*, Section A, Item.1, Maintenance Material Bond shall control when the Contractor shall repair all defective chip seal."

### 2.12 Damage Claims

Sub-Section 107-09, Damage, of the Standard Specifications shall apply to this contract except as modified herein. The Contractor's responsibility for damage includes, but is not limited to, all claims of damages to vehicles and/or injuries to bicyclists or pedestrians traveling on the highway right of way of roads surface treated under this contract caused by loose stone and/or excess bituminous material until final acceptance by the Authorized User. Final acceptance of the chip seal project shall not occur until 72 hours after the completion of the chip seal project. The Contractor shall supply the Authorized User Representative with a name and address where damage and/or injury claims should be sent.

### 2.13 Work Zone Traffic Control

The Contractor shall be responsible for work zone traffic control. Traffic shall be controlled in accordance with the Manual of Uniform Traffic Control Devices (MUTCD) and Sections 619-1 through 619-3 of the Standard Specifications including modifications to the Standard Specifications. The Contractor shall submit a Work Zone Traffic Control Plan for approval to the Resident Engineer at the Pre-Chip Seal Meeting. For two-way roadways, NYSDOT 619 Standard Sheets 619-307, 619-308, 619-309, 619-312 and 619-314 may be used as a basis for development of a Work Zone Traffic Control Plan. For one-way roadways, NYSDOT 619 Standard Sheets 619-302, 619-303, and 619-313 may be used as a basis for development of a Work Zone Traffic Control Plan. For one-way Freeways or Expressways, NYSDOT 619 Standard Sheets 619-301, 619-302, 619-304, and 619-305 may be used as a basis for development of a Work Zone Traffic Control Plan. A link to NYSDOT 619 Standard Sheets can be found on Attachment 14 – *NYSDOT Work Zone Traffic Control* included within this Invitation for Bids.

All necessary flaggers for traffic control shall be provided by the Contractor. A minimum of three flaggers shall be provided while the chip seal operation is underway. One shall be stationed at each end of the operation, and one shall be stationed with the aggregate spreader. The Contractor shall station flaggers such that communication is maintained between the flaggers. Hand signals, radios, pilot vehicles, or some other means of communication may be used subject to the approval of the Authorized User. The requirements for Pilot Vehicles and details about traffic opening are listed in the NYSDOT Standard Specifications under CONSTRUCTION DETAILS, 410-3.02 Chip Seal, D. Opening to Traffic. The Contractor shall provide construction signs as specified in Section 619-1 through 619-3 of the Standard Specifications and in the MUTCD.

Major intersecting roads are defined as State, County, Town, Village, or City roads. The Contractor may provide portable signs as shown in Figure 6F-2 of the MUTCD and meeting the requirements of Section 619 of the Standard Specifications for lane closures during work hours.

With prior permission of the State's Resident Engineer or Authorized User Representative, the Contractor may provide portable signs as shown in Figure 6F-2 of the MUTCD for the above referenced DO NOT PASS and NO CENTER LINE signs. Signs left active at night shall be rigid and reflectorized in accordance with the Standard Specifications. The Contractor shall be responsible for assuring that these signs will be in their upright, visible positions twenty-four hours a day, seven days a week while 2'x 4' temporary yellow markings are used instead of full barrier pavement markings.

LOT 2: CHIP SEAL (Cont'd)

At a minimum, the Contractor shall install the following permanent construction signs supplemented by temporary signs as needed:

Sign	Minimum Size	Location
ROAD WORK NEXT _____ MILES	<u>G20-1</u> 36" x 18"	On main line upstream of project in each direction.
END ROAD WORK	<u>G20-2</u> 36" x 18"	On main line after end of project in each direction.
ROAD WORK AHEAD	<u>W20-1</u> 36" x 36"	On main line in advance of the affected highway segment in each direction and on major intersecting roads 300 -500 feet in advance of main line. Sign should be covered if it conflicts with temporary signing in the vicinity. (Place between the G20-1 and the first warning sign that states condition- i.e. W8-12, W8-9 or W8-15).
DO NOT PASS	<u>R4-1G</u> 24" x 30"	If 2'x 4" temporary yellow markings are used instead of full barrier centerline pavement markings, place the first sign at or within 100-feet of the beginning of the unmarked area, second within 1,000-feet and subsequent signs, spaced every ½ mile along project in each direction.
NO CENTER LINE	<u>W8-12</u> 36" x 36"	If 2'x 4" temporary yellow markings are used instead of full barrier centerline pavement markings, place the first sign in advance of the condition and the first "DO NOT PASS" sign: 300' urban is preferred (100' minimum), 500' rural is preferred (200' minimum). Place additional signs spaced every 2 miles on mainline in each direction and after every major intersecting road.
LOW SHOULDER	<u>W8-9</u> 36" x 36"	Place on mainline spaced every 2 miles along project in each direction and after each intersecting road until shoulder back-up is installed (if conditions warrant use, place between W8-12 and R4-1, maintaining a minimum of 200' between signs for rural roads and 100' on urban. The W8-12 can be moved upstream to accommodate the required spacing).
LOOSE GRAVEL	<u>W8-7</u> 36" x 36"	Place on mainline at start of the project and spaced every ½ mile along project in each direction.
30 MPH	<u>W13-1P</u> 18" x 18"	Mounted on W8-7 LOOSE GRAVEL sign.
PILOT VEHICLE FOLLOW ME	<u>G20-4</u> 36" x 18"	On back of pilot vehicles.

\*\*All signs should maintain an absolute minimum spacing of 200' rural or 100' urban. 500' is preferred on rural and 300' is preferred on urban. Double stacking of any of the above signs (or combination thereof) will NOT be permitted.

LOT 2: CHIP SEAL (Cont'd)

**2.13.1 Special Note - Temporary Pavement Markings**

The Contractor shall install and maintain temporary pavement markings on any paved surface without permanent pavement markings before opening it to traffic, before nightfall or before the end of the workday, whichever comes soonest except for areas that are open during the work shift with channelizing devices or flaggers. Temporary pavement markings shall meet the requirements of Section 619 of the Standard Specifications except that two-lane, two-way highways may be left without full barrier centerlines in no passing zones for a maximum of 7 calendar days provided that NO CENTER LINE (W8-12, black on orange), NO PASSING ZONE (W14-3, black on orange pennant shaped sign), and DO NOT PASS (R4-1) signs are used consistent with the MUTCD and in conjunction with yellow 2-foot by 4-inch temporary markings consisting of retro-reflective removable pavement marking tape, paint or yellow temporary overlay markers installed on a 40 ft. cycle to delineate the centerline location.

The Authorized User is responsible for the final pavement markings unless otherwise indicated in the contract. If the Contractor chooses to install NO CENTER LINE and DO NOT PASS signs and temporary yellow 2-foot by 4-inch pavement markings in lieu of full barrier centerline markings, the signs shall be left in place until the Authorized User has completed installing the final pavement markings. The Authorized User will normally complete final pavement markings within 7 days of the project completion. However, if unavoidable situations delay the pavement marking installation the signs shall remain in place for 14 calendar days after the project has been completed or until the Authorized User has completed installing the final pavement markings, whichever comes first. If permanent pavement marking cannot be installed within 14 days of the project completion, the Authorized User must install interim pavement marking including center lines, edge lines, stop bars, and simple crosswalks with no hatching before the end of 14 days after project completion.

All costs for Work Zone Traffic Control including flagging, temporary pavement markings, pilot vehicle, delineation, and construction signs are to be included in the prices bid per square yard of chip seal and cover sand (if required). No separate payment shall be made.

The work zone traffic control provisions in this section shall apply for any work performed pursuant to the Maintenance Material Bond.

**2.13.2 Additional Flaggers for Work Zone Traffic Control**

If the Engineer or Authorized User Representative determines that more than three flaggers are necessary to properly control traffic on two-way roadways or more than two flaggers are necessary to properly control traffic on one-way roadways, the Contractor shall provide additional flaggers under the Additional Flaggers item. The price bid per flagger per day shall include all costs of providing a flagger where directed by the Engineer or Authorized User Representative with all the necessary safety equipment, i.e. stop/slow paddle, flag, vest, hardhat, etc. Payment shall be by the day for each flagger provided. A day shall be determined as including the time period between the commencement and completion of work on any calendar day. No extra payment shall be provided if the Contractor elects to work a longer day than the standard eight-hour workday. Payment shall be made to the nearest quarter day as determined by the Engineer or Authorized User Representative.

**2.13.3 Abrading Existing Pavement Markings with Work Zone Traffic Control by the Contractor**

The Contractor shall remove any epoxy, thermoplastic, preformed tape or high built waterborne pavement markings. Other markings shall be removed as ordered by the Engineer or the Authorized User Representative. The method of abrading may include sand blasting, water blasting, grinding, or other methods approved by the Engineer or Authorized User Representative. Care shall be taken to avoid damage to passing traffic. All damage to passing traffic caused by the Contractor's operations shall be the Contractor's responsibility. Waste materials generated by the abrading operation shall be cleaned up and disposed of by the Contractor. The Contractor shall place interim pavement markings as specified elsewhere in this Invitation for Bids under work zone traffic control; unless the chip seal will be placed the same day as pavement markings are abraded. The Contractor shall make every effort to expeditiously place the paving material in areas where pavement markings have been abraded, and temporary pavement markings are in place. Under no circumstances will temporary pavement markings be allowed for more than five calendar days in areas where pavement markings have been abraded. In this event, the Contractor shall be required to place full pavement markings at no cost to the Authorized User. During the pavement markings abrading operation, traffic will be controlled by the Contractor in accordance with the Work Zone Traffic Control requirements included herein. The Contractor shall submit a proposed Work Zone Traffic Control Plan to the Engineer or Authorized User Representative for approval. The plan may be based on the Work Zone Traffic Control included in this Invitation for Bids see Attachment 14 – *NYS DOT Work Zone Traffic Control*.

LOT 2: CHIP SEAL (Cont'd)

Payment will be made by the linear foot of pavement marking 4-inches wide. Payment for pavement markings wider than 4-inches or for pavement marking symbols will be made by the following method:

$$\frac{\text{Width of marking (inches)} \times \text{Linear Feet}}{4\text{-inches}}$$

The price bid for pavement marking abrading shall include all labor, materials, and equipment required to abrade the existing pavement markings and to properly control traffic to the satisfaction of the Engineer or Authorized User Representative.

**2.13.4 Special Note: Work Zone Intrusion Initiative**

As part of the NYS Department of Transportation's Work Zone Intrusion Initiative, the following countermeasures shall apply to this Invitation for Bids.

**Channelizing Device Spacing Reduction**

A maximum channelizing device spacing of 40-feet shall be provided at stationary work sites where workers are exposed to traffic. This spacing shall be maintained at a reasonable distance upstream of workers and shall be used throughout the work zone.

Where tapers are located less than 500-feet from the work site, the 40-foot spacing shall be used in the taper as well.

Drums or vertical panels are preferred for long-term stationary and intermediate-term stationary work zones, and at any locations where the risk of intrusion is high. Traffic cones are normally adequate for work zones set up and removed on a daily basis.

In long lane or shoulder closures, at least two channelizing devices shall be placed transversely at maximum 800 ft. intervals to discourage traffic from driving through the closed lane. **Transversely placed devices are not required where pilot cars are in use.**

Frequent checks shall be made to reset channelizing devices dislodged by traffic.

**Flagger Station Enhanced Setups**

Additional cones and a flag tree meeting section 6F.62 of the MUTCD shall be used upstream of flagger stations to provide added warning to drivers. These devices shall be used for flagger stations except those that are constantly moving or are in use at one location for no more than a few minutes. If the W20-7a Flagger sign is required, the additional cones and flag tree shall also be used.

For additional details on Flagger Station Enhanced Setups, see Attachment 14 – *NYS DOT Work Zone Traffic Control* included in this Invitation for Bids.

**2.14 Detailed Specifications – Chip Seal**

Please, see Attachment 11 - *Detailed Specifications – Liquid Bituminous Materials*.

## LOT 3: COLD RECYCLING

### 3.1 Introduction

Cold Recycling of bituminous concrete pavements is a corrective maintenance technique. The existing pavement is milled off for a depth of 3 to 4 inches, a liquid bituminous material is added to the millings, and the resulting mixture is placed and compacted on the milled surface. A new bituminous concrete sealing layer is added later. Existing cracks are eliminated, and the resulting pavement should last for many years.

### 3.2 Pricing Information

#### 3.2.1 General

Price quoted shall be to three (3) decimal places. Price quoted shall be F.O.B. the Contractor's location per square yard for the Cold Recycling (In-Place and/or Central Plant), at the project site for the additional cost for small and/or short projects and for the shoulder milling, F.O.B. the Contractor's location per gallon for the liquid bituminous material for cold recycling and for fog sealing (if required) delivered to the location specified by the Authorized User per ton for the aggregate, and per ton for Portland cement (if required).

Cold Recycling shall be performed in accordance with NYSDOT's Standard Specifications and as per the attached specification for Cold Recycling. Shoulder milling shall be performed as per these specifications. Cleaning and preparing the existing pavement will be the responsibility of the Authorized User. Erecting warning signs and directing traffic will be the responsibility of the Authorized User or the Contractor using the optional work zone traffic control section at the discretion of the Authorized User.

Price quoted for Optional Work Zone Traffic Control shall be per square yard.

Price quoted for additional flaggers (if required) shall be net per day (to the nearest quarter day) for additional flaggers.

Price quoted for rumble strips (if required) shall be net per each linear foot of rumble strips both installed and removed (i.e., one price includes both installation and removal of rumble strips) at the project locations.

Price quoted for mobilization from Contractor's location to project location shall be per square yard

Price quoted for heating, hauling, and applying the asphalt emulsion or PG Binder used in cold recycling and asphalt emulsion used in fog sealing (if required) from Contractor's location to project location shall be net per gallon of asphalt emulsion or PG Binder used in cold recycling and fog sealing.

**Price additional for small projects or projects recycled in short lengths:** Price for small projects (less than 20,000 square yards) or projects where 50% of the total area must be recycled in lengths less than 1,500-feet shall be the price bid for 20,000 square yards to 50,000 square yards for the appropriate depth. An additional price for small projects or projects where 50% of the total area must be recycled in lengths less than 1,500-feet shall be quoted and added to this price.

#### 3.2.2 Insurance

Please refer to Section 6.19 - Insurance of the Invitation for Bids for information about insurance.

**LOT 3: COLD RECYCLING (Cont'd)**

**3.3 Asphalt Price Adjustments – Cold Recycling**

**3.3.1 General**

- a. Asphalt price adjustments allowed will be based on the November 1, 2025 average of the F.O.B. terminal price per ton of unmodified PG 64S-22 binder without anti-stripping agent (base average F.O.B. terminal price). The new monthly average terminal price will be determined by the New York State Department of Transportation based on prices of pre-approved primary sources of performance graded binder in accordance with the New York State Department of Transportation Standard Specification.

**The November 1, 2025 average is \$638.000**

**NOTE:** The same grade of asphalt cement used in establishing the base average F.O.B. terminal price shall be used in establishing the new average F.O.B. terminal price.

In the event that one or more of the New York State Department of Transportation pre-approved sources discontinue posting a price for asphalt cement, the base average F.O.B. terminal **price shall not be recalculated.**

- b. The new average F.O.B. terminal price will be determined based on the above F.O.B. terminal prices posted each month during the contract period. However, asphalt price adjustments, in accordance with the formula below, will be effective for deliveries made on and after the first of the month following the adjustment date.
- c. The unit prices of bituminous materials purchased from any award based on this specification will be subject to adjustment based on the following formula:

Price Adjustment (per gallon)	=	<table style="width: 100%; border-collapse: collapse;"> <tr> <td style="width: 50%; border-bottom: 1px solid black;">New Monthly Average FOB Terminal Price</td> <td style="width: 5%; text-align: center;">-</td> <td style="width: 45%; border-bottom: 1px solid black;">Base Average Terminal Price</td> </tr> <tr> <td colspan="3" style="border-top: 1px solid black; padding-top: 5px;">235</td> </tr> </table>	New Monthly Average FOB Terminal Price	-	Base Average Terminal Price	235			X	Total Allowable Petroleum %
New Monthly Average FOB Terminal Price	-	Base Average Terminal Price								
235										

Positive Price Adjustment number shall be added to original per gallon Bid Price.

Negative Price Adjustment number shall be subtracted from original per gallon Bid Price.

**New Monthly Average F.O.B. Terminal Price**

The average F.O.B. terminal price for unmodified PG 64S-22 binder without anti-stripping agent is as determined by the New York State Department of Transportation per New York State Department of Transportation Standard Specification.

**Base Average F.O.B. Terminal Price**

The average F.O.B. terminal price of unmodified PG 64S-22 binder without anti-stripping agent is as determined by the New York State Department of Transportation as of November 1, 2025.

**LOT 3: COLD RECYCLING (Cont'd)**

**Total Allowable Petroleum**

The percentage of total allowable petroleum for each item is as follows:

Material Designation	Grade	Asphalt %	Petroleum Allowance %	Total Allowable Petroleum %
702-3201	MS-2	65.0	8.2	73.2%
702-3301	HFMS-2	65.0	8.2	73.2%
702-3401	HFMS-2h	65.0	2.7	67.7%
702-3402	HFMS-2s	65.0	8.2	73.2%
702-3501	SS-1	65.0	0.2	65.2%
702-3601	SS-1h	65.0	0.2	65.2%
702-4201	CMS-2	65.0	10.2	75.2%
702-4301	CMS-2h	65.0	10.2	75.2%
702-4401	CSS-1	65.0	0.2	65.2%
702-4501	CSS-1h	65.0	0.2	65.2%
	PG 64S-22	100.0	0.2	100.2%

Asphalt Price Adjustments will not be allowed for materials which do not have an asphalt cement base.

- d. Work performed after the expiration of the contract, where no extension has been granted, resultant from purchase orders placed prior to expiration of the contract will be based on the new average for the month in which the work is done applying the same base established for that contract.

Asphalt Price Adjustments for any contracts that are extended will be based on the new average for the month in which the work is done applying the same base established for that contract.

- e. Asphalt Price Adjustments allowed by this contract shall be calculated and applied to the original prices. There will not be Asphalt Price Adjustments unless the change amounts to more than \$0.010 per gallon from the original price. In these instances, prices will revert back to the original prices.
- f. All Asphalt Price Adjustments will be computed to three decimal places.
- g. Should these provisions result in a price structure which becomes unworkable, detrimental or injurious to the State or in prices which are not truly reflective of market conditions or which are deemed by the Commissioner to be unreasonable or excessive, and no adjustment in price is mutually agreeable, the Commissioner reserves the sole right upon ten days written notice mailed to the Contractor to terminate any contract resulting from this bid opening.
- h. All Asphalt Price Adjustments shall be published by the State and issued to all contract holders whose responsibility will be to attach the appropriate State notification (based on when the work was performed) to the payment invoice submitted to Authorized User.

**3.3.2 Asphalt Price Adjustment – Cold Recycling: Example**

This example is for illustration purposes only. Actual Base Average Price, etc., may vary.

Material Designation 702-3301

Base Average Price = \$638.000

New Average Price = \$648.000

% Total Allowable Petroleum = 73.2%

**LOT 3: COLD RECYCLING (Cont'd)**

Price Adjustment (per gallon)	=	$\frac{(648.000 - 638.000)}{235}$	X	0.732
-------------------------------------	---	-----------------------------------	---	-------

Price Adjustment (per gallon)	=	+\$0.031 per gallon
-------------------------------------	---	---------------------

Positive Price Adjustment number shall be added to original per gallon Bid Price.  
Negative Price Adjustment number shall be subtracted from original per gallon Bid Price.

**3.4 Minimum Project Size**

The minimum project size for Cold Recycling under this contract without an extra charge shall be 20,000 square yards. This is approximately 1.7 miles of two-lane highway at 20-feet wide. A quantity/price change occurs at 50,000 square yards, which is approximately 4.2 miles of a 2-lane highway at 20-feet wide.

The minimum width of shoulder milling shall be 2-feet. The minimum quantity of shoulder milling shall be 4,000 square yards. A quantity/price change occurs at 20,000 square yards.

An additional cost, bid by the Contractor, shall be assessed per square yard for projects less than 20,000 square yards or on any projects where more than 50% of the total area (square yards) must be recycled in short lengths (less than 1,500-feet in length).

**3.5 Delivery Ticket**

A delivery ticket shall be provided with each load of bituminous asphalt emulsions stating the following:

1. Storage facility identification
2. Ticket Number
3. Date/Time
4. Item Number and Type
5. Quantity ticket printed by machine
6. Quantity in 60°F gallons for emulsions.

**3.6 Payment**

Payment for Cold Recycling of Asphalt Concrete shall be made at the contract price per unit bid for the actual number of square yards of recycling at 3-inches or 4-inches deep, the actual number of square yards of shoulder milling (and disposal if required) at 3-inches or 4-inches deep, the actual number of tons of aggregate, the actual number of tons of Portland cement, the actual number of gallons of asphalt emulsion at 60°F, the actual number of gallons of PG binder, and the actual number of gallons of fog seal verified by Authorized User in the accepted portion of the work. The determination as to quantities involved in any contract shall be accepted as final and binding upon the Contractor.

If the Engineer or Authorized User Representative orders the Contractor to spread the recycled mixture over a wider area than the milled area, the Contractor shall be due extra compensation for the non-milled area. The actual number of square yards not milled but covered by recycled material shall be measured in square yards and payment for that area shall be computed at 50 percent of the bid price for recycling plus mobilization.

If the Authorized User orders the Contractor to recycle a project less than 20,000 square yards in area or a project where the total area to be recycled must be recycled in short lengths (less than 1,500-feet in length) the Contractor shall be paid the amount bid per square yard for small projects and/or short projects for the actual number of square yards of accepted Cold Recycling. If the project is both small (less than 20,000 square yards) and also must be recycled in short lengths (less than 1,500-feet in length) then only one additional payment for small and/or short lengths projects shall be made. If the project is small or must be recycled in short lengths, payment for the Cold Recycling itself shall be made per square yard of accepted Cold Recycling at the price bid for 20,000 square yards to 50,000 square yards for the appropriate depth. Even if the project is both small and has short segments, only one surcharge per square yard shall be paid.

## LOT 3: COLD RECYCLING (Cont'd)

A delivery slip stating quantities of asphalt emulsions (with or without additive) or PG Binder for cold recycling and asphalt emulsions for fog sealing (if required) shall accompany each shipment. An invoice listing the quantities of Cold Recycling, asphalt emulsions or PG Binder, fog sealing (if required), and aggregate shall be sent promptly by the Contractor to the Engineer or Authorized User Representative.

No separate payment will be made for the use of water in the mixing process.

Any work required for the maintenance and repair of the Cold Recycling by the Contractor during the curing period and for an additional twenty days thereafter shall be done at the Contractor's expense.

Payment for optional work zone traffic control (if required) will be made based on the number of square yards of cold recycling and if used shoulder milling. Payment for additional flaggers (if required) will be made based on the number of days (computed to the nearest quarter day) that additional flaggers are utilized as directed by the Engineer or Authorized User Representative.

Payment for rumble strips (if required) will be based on the number of linear feet of rumble strips that are actually installed and removed as per the specifications included herein.

Payment for optional pilot vehicles with drivers will be made based on the number of days (computed to the nearest quarter day) that optional pilot vehicles with drivers are utilized as directed by the Engineer or the Authorized User Representative.

The price per unit arrived at (mutually estimated) by the Contractor and the Authorized User on the Price Calculation Worksheet or the price per unit resultant from the quick quote process (whichever is applicable) shall be the price per unit paid to the Contractor. The quantity of asphalt emulsions or PG Binder per square yard for Cold Recycling and asphalt emulsions used for fog sealing shall be considered binding upon the Contractor.

### 3.7 Pre-Recycling Meeting

The Contractor shall schedule a Pre-Recycling Meeting with the affected Resident Engineer or Authorized User Representative after the acceptance of the mix design by the Authorized User and at least one week prior to the start of the recycling. Project-level supervisors for both the Authorized User and the Contractor will be present at this meeting. At this meeting the Contractor shall present Certificates of Insurance evidencing compliance with the additional insurance requirements, their proposed recycling schedule, procedure and Traffic Control Plan (if applicable) to the Authorized User for approval. Prior to the start of recycling, the Contractor shall coordinate the details of the recycling with the Resident Engineer or Authorized User Representative.

### 3.8 Supervision

The Resident Engineer or Authorized User Representative shall provide supervision for the Cold Recycling operation. The Resident Engineer or Authorized User Representative shall designate a recycling supervisor, and that person shall be in charge of and responsible for the operation. The following portions of Section 105 - CONTROL OF WORK of the Standard Specifications shall apply to these projects: 105-01 ENGINEER'S AUTHORITY, 105-05 VENDOR RESPONSIBILITY, 105-06 COOPERATION WITH UTILITIES AND OTHER CONTRACTORS.

### 3.9 Work Hours

Work will not be permitted on Sundays and Holidays. If the Contractor desires to work overtime on other days, dispensation from the NYS Labor Department must be obtained using Department of Labor Form PW-30.

## LOT 3: COLD RECYCLING (Cont'd)

### 3.10 Mix Design

Cold recycling mix designs may be developed by two different methods under this contract. The first method will require that the Authorized User will core the pavement. The Contractor will specify the amount of added aggregate and will be responsible for specifying the type and amount of asphalt emulsion or PG Binder to properly recycle the pavement. The Contractor will also specify the rate of asphalt emulsion required for fog sealing.

The second method is the same as the first method shown above, except that the Contractor will also core the pavement. After a Contractor receives a verbal or written request for a mix design for a specific pavement section:

**From the NYS Department of Transportation (NYSDOT)**, the Contractor must supply a mix design for approval to the NYSDOT Director of Materials Bureau within 15 workdays unless additional time is granted by the Resident Engineer. Copies shall be sent according to Attachment 11 - *Detailed Specifications – Liquid Bituminous Materials*.

Core holes drilled by the Contractor to derive information for a mix design must be filled the day drilled with cold mix bituminous concrete approved by the Resident Engineer. Traffic control for the coring operation shall be performed by the Contractor with prior approval of the lane closure scheme by the Resident Engineer.

**From an Authorized User other than the NYSDOT**, the Contractor must supply a mix design for approval to the Authorized User Representative within 15 workdays unless additional time is granted by the Authorized User Representative. Copies shall be sent to the Authorized User Representative or their designee. The contact information shall be supplied to the Contractor by the Authorized User Representative.

Core holes drilled by the Contractor to derive information for a mix design must be filled the day drilled with cold mix bituminous concrete approved by the Authorized User Representative. Traffic control for the coring operation shall be performed by the Contractor with prior approval of the lane closure scheme by the Authorized User Representative.

### 3.11 Coring by the Contractor for Non NYSDOT Projects

If the Contractor is responsible for the mix design, this section will apply. Use 6-inch diameter cores to determine the asphalt content and aggregate gradation of the pavement to be recycled. The Authorized User Representative will designate the locations from which the cores will be taken. One location will be designated for each lane mile of pavement with a minimum of six cores for each mix design. Core locations should be uniformly spaced along the length of the project and designated in alternating lanes.

If shoulders are included in the reclaimed material, take a minimum of six additional cores from the shoulders for the mix design. If the pavement or shoulder condition, such as material type or overlay history, changes at some point in the project a separate mixture design will be generated using a separate set of core locations. Follow the same coring and design procedures for each additional mixture design.

The Authorized User Representative will approve the plan for work zone traffic control before any coring takes place. Take all pavement cores from the center of the lane within 10-feet of the location marked by the Authorized User Representative. Take all shoulder cores within 2-feet of the outer edge of the shoulder and 10-feet of the location marked by the Authorized User Representative.

Submit a completed mixture design form to the Authorized User Representative for approval. In addition to the information required on the design form, provide the following information:

1. Core locations.
2. Depth of asphalt pavement at each core location.
3. Aggregate gradation and asphalt content of each core from the portion of the core representing the pavement to be recycled. List pavement cores separately from shoulder cores.
4. Average of all gradation and asphalt content results. When the design contains both pavement and shoulder cores, weight the average appropriately to reflect the proper proportion of shoulder material and pavement material to be recycled.
5. Gradation of additional aggregate.
6. The combined gradation of the average core gradation and the additional aggregate.
7. Graph showing the average core gradation, combined gradation, and the mix design control limits plotted on a graph of percent passing v. sieve size raised to the 0.45 power.
8. Completed Quick Quote Worksheet (if necessary).

## LOT 3: COLD RECYCLING (Cont'd)

### 3.12 Shoulder Milling

If the Engineer or Authorized User Representative orders the Contractor to mill out unsuitable material from the shoulders, the Contractor shall do so in compliance with this section. Material shall be removed from shoulders (a minimum of 2-feet in width) by suitable milling machines and removed from the project site by the Contractor or by the Authorized User. When removal and disposal by the Contractor is specified, the Contractor shall be required to remove and dispose of the material at their own expense. When removal and disposal by the Authorized User is specified, the Contractor shall load the material into Authorized User trucks for disposal. Shoulder milling shall be 3-inches or 4-inches deep as specified by the Engineer or Authorized User Representative. The resulting surface of shoulder milling shall be in reasonably close conformity with the grades and cross slopes of the shoulder as originally constructed, except for the elevation change.

### 3.13 Restoration of Disturbed Areas

During the course of the work, the Contractor shall take reasonable care not to disturb areas outside the existing pavement. Any areas disturbed by the Contractor shall be returned to their original condition at no expense to the owner. Any and all debris generated as part of the work shall be removed by the Contractor upon completion of the project.

### 3.14 Optional Work Zone Traffic Control

The Contractor shall submit a per square yard price for work zone traffic control as prescribed by this specification. When requesting mix designs from the Contractors, the Authorized User may, at their option, include work zone traffic control by the Contractor for the specific project anticipated.

If optional work zone traffic control is included in the quick quoting process, the Contractor shall be responsible for Work Zone Traffic Control. Traffic shall be controlled in accordance with the Manual of Uniform Traffic Control Devices (MUTCD) and Sections 619-1 through 619-3 of the Standard Specifications including modifications to the Standard Specifications. The Contractor shall submit a Work Zone Traffic Control Plan for approval to the Resident Engineer at the Pre-Cold Recycling Meeting. For two-way roadways, NYSDOT 619 Standard Sheets 619-307, 619-308, 619-309, 619-312 and 619-314 may be used as a basis for development of a Work Zone Traffic Control Plan. For one-way roadways, NYSDOT 619 Standard Sheets 619-302, 619-303, and 619-313 may be used as a basis for development of a Work Zone Traffic Control Plan. For one-way Freeways or Expressways, NYSDOT 619 Standard Sheets 619-301, 619-302, 619-304, and 619-305 may be used as a basis for development of a Work Zone Traffic Control Plan. A link to NYSDOT 619 Standard Sheets can be found on Attachment 14 – *NYSDOT Work Zone Traffic Control* included within this Invitation for Bids.

All necessary flaggers for traffic control shall be provided by the Contractor. A minimum of three flaggers shall be provided while the recycling operation is underway. One shall be stationed at each end of the operation, and one shall be stationed with the milling machine/paver. The Contractor shall station flaggers such that communication is maintained between the flaggers. Hand signals, radios, pilot vehicles, or some other means of communication may be used subject to the approval of the Resident Engineer or Authorized User Representative.

The Contractor shall provide construction signs as specified in Section 619-1 through 619-3 of the Standard Specifications and in the MUTCD.

At a minimum the Contractor shall install the following permanent construction signs (see next page):

LOT 3: COLD RECYCLING (Cont'd)

Sign	Minimum Size	Location
ROAD WORK NEXT ____ MILES	<u>G20-1</u> Conventional 36" x 18"  Freeways 48" x 24"	On main line upstream of project in each direction.
END ROAD WORK	<u>G20-2</u> Conventional 36" x 18"  Freeways 48" x 24"	On main line after end of project in each direction.
ROAD WORK AHEAD	<u>W20-1</u> Conventional 36" x 36"  Freeways 48" x 48"	On main line in advance of the affected highway segment in each direction and on major intersecting roads 300-500 feet in advance of main line. Sign should be covered if it conflicts with temporary signing in the vicinity. (Place between the G20-1 and the first warning sign that states condition - i.e. W8-12, W8-9 or W8-15).
DO NOT PASS	<u>R4-1</u> Conventional 24" x 30"	If 2'x 4" temporary yellow markings are used instead of full barrier centerline pavement markings, place the first sign at or within 100-feet of the beginning of the unmarked area, second within 1,000-feet and subsequent signs, spaced every ½ mile along project in each direction.
NO CENTER LINE	<u>W8-12</u> Conventional 36" x 36"	If 2'x 4" temporary yellow markings are used instead of full barrier centerline pavement markings, place the first sign in advance of the condition and the first "DO NOT PASS" sign: 300' urban is preferred (100' minimum), 500' rural is preferred (200' minimum). Place additional signs spaced every 2 miles on mainline in each direction and after every major intersecting road.
LOW SHOULDER	<u>W8-9</u> Conventional 36" x 36"  Freeways 48" x 48"	Place on mainline spaced every 2 miles along project in each direction and after every major intersecting road until shoulder back-up is installed (if conditions warrant use, place between the W8-12 and R4-1, maintaining a minimum of 200' between signs for rural roads and 100' on urban. The W8-12 can be moved upstream to accommodate the required spacing.)
GROOVED PAVEMENT	<u>W8-15</u> Conventional 36" x 36"  Freeways 48" x 48"	On any roadway 500-feet in advance of rebates milled under this contract but not paved. Remove or cover after paving rebate.

\*\*All signs should maintain an absolute minimum spacing of 200' rural or 100' urban. 500' is preferred on rural and 300' is preferred on urban. Double stacking of any of the above signs, or combination thereof, will NOT be permitted.

Major intersecting roads are defined as State, County, Town, Village, or City roads. The Contractor may provide portable signs as shown in Figure 6F-2 of the MUTCD and meeting the requirements of Section 619 of the Standard Specifications for lane closures during work hours.

With prior permission of the Resident Engineer or Authorized User Representative, the Contractor may provide portable signs as shown in Figure 6F-2 of the MUTCD for the above referenced DO NOT PASS and NO CENTER LINE signs. Signs left active at night shall be rigid and reflectorized in accordance with the Standard Specifications. The Contractor shall be responsible for assuring that these signs will be in their upright, visible positions twenty-four hours a day, seven days a week while 2'x 4' temporary yellow markings are used instead of full barrier pavement markings.

## LOT 3: COLD RECYCLING (Cont'd)

Whenever traffic is permitted to use a travel lane and the adjacent shoulder is not brought up to grade, construction warning signs meeting the requirements of 6F.42 of the MUTCD sign shall be placed.

### 3.14.1 Special Note - Temporary Pavement Markings

The Contractor shall install and maintain temporary pavement markings on any paved surface without permanent pavement markings before opening it to traffic, before nightfall or before the end of the workday, whichever comes soonest except for areas that are open during the work shift with channelizing devices or flaggers. Temporary pavement markings shall meet the requirements of Section 619 of the Standard Specifications except that two-lane, two-way highways may be left without full barrier centerlines in no passing zones for a maximum of 7 calendar days provided that NO CENTER LINE (W8-12, black on orange), NO PASSING ZONE (W14-3, black on orange pennant shaped sign), and DO NOT PASS (R4-1) signs are used consistent with the MUTCD and in conjunction with yellow 2-foot by 4-inch temporary markings consisting of retro-reflective removable pavement marking tape, paint or yellow temporary overlay markers installed on a 40-foot cycle to delineate the centerline location.

The Authorized User is responsible for the final pavement markings unless otherwise indicated in the contract. If the Contractor chooses to install NO CENTER LINE and DO NOT PASS signs and temporary yellow 2-foot by 4-inch pavement markings in lieu of full barrier centerline markings, the signs shall be left in place until the Authorized User has completed installing the final pavement markings. The Authorized User will normally complete final pavement markings within 7 days of the project completion. However, if unavoidable situations delay the pavement marking installation the signs shall remain in place for 14 calendar days after the project has been completed or until the Authorized User has completed installing the final pavement markings, whichever comes first. If permanent pavement marking cannot be installed within 14 days of the project completion, Authorized User must install interim pavement marking including center lines, edge lines, stop bars, and simple crosswalks with no hatching before the end of 14 days after project completion.

All costs for Work Zone Traffic Control including flagging, temporary pavement markings, delineation, and construction signs are to be included in the prices bid per square yard for optional work zone traffic control. No separate payment shall be made.

### 3.14.2 Additional Flaggers for Work Zone Traffic Control

If the Engineer or Authorized User Representative determines that more than 3 flaggers are necessary to properly control traffic on two-way roadways or more than 2 flaggers are necessary to properly control traffic on one-way roadways and the Contractor is responsible for Work Zone Traffic Control under this Invitation for Bids, the Contractor shall provide additional flaggers under the Additional Flaggers item. The price bid per flagger per day shall include all costs of providing a flagger where directed by the Engineer or Authorized User Representative with all the necessary safety equipment, i.e., stop/slow paddle, flag, vest, hardhat, etc. Payment shall be by the day for each flagger provided. A day shall be determined as including the time period between the commencement and completion of work on any calendar day. No extra payment shall be provided if the Contractor elects to work a longer day than the standard eight-hour workday. Payment shall be made to the nearest quarter day as determined by the Engineer or Authorized User Representative.

## LOT 3: COLD RECYCLING (Cont'd)

### 3.14.3 Work Zone Traffic Intrusion Initiative

**(Attention - Special Note):** As part of the NYS Department of Transportation's Work Zone Intrusion Initiative, the following countermeasures shall be applied to Cold Recycling Projects in this Invitation for Bids if the Contractor is responsible for Optional Work Zone Traffic Control:

#### **Channelizing Device Spacing Reduction**

A maximum channelizing device spacing of 40-feet shall be provided at stationary work sites where workers are exposed to traffic. This spacing shall be maintained a reasonable distance upstream of workers and shall be used throughout the work zone.

Where tapers are located less than 500-feet from the work site the 40-foot spacing shall be used in the taper as well.

Drums or vertical panels are preferred for long-term and intermediate-term work zones, and at any locations where the risk of intrusion is high. Traffic cones are normally adequate for work zones set up and removed on a daily basis.

In long lane or shoulder closures, at least two channelizing devices shall be placed transversely at maximum 800-foot intervals to discourage traffic from driving through the closed lane. **Transversely placed devices are not required where pilot cars are in use.**

Frequent checks shall be made to reset channelizing devices dislodged by traffic.

#### **Flagger Station Enhanced Setups**

Additional cones and a flag tree meeting the requirements of Section 6F.62 of the MUTCD shall be used upstream of flagger stations to provide added warning to drivers. These devices shall be used for flagger stations except those that are constantly moving or are in use at one location for no more than a few minutes. If the W20-7a Flagger sign is used, the additional cones and flag tree shall also be used.

For additional details on Flagger Station Enhanced Setups, see Attachment 14 – *NYS DOT Work Zone Traffic Control* included in this Invitation for Bids.

#### **Temporary Rumble Strips**

##### **a. Description**

This work shall consist of the installation, maintenance and subsequent removal of temporary rumble strips in Cold Recycling work zones where indicated in the Invitation for Bids or as directed by the Engineer or Authorized User Representative.

##### **b. Materials**

Rumble strips shall be either constructed in place from a raised strip of asphalt concrete or constructed in place with removable pavement marking tape. Raised removable tape rumble strips shall be formed by applying four layers of removable black non-reflectorized removable pavement marking tape. The tape shall be applied to a clean, dry pavement surface in accordance with the manufacturer's recommendations. The pavement surface shall be cleaned with compressed air just prior to application of the tape.

Raised asphalt rumble strips shall be formed from asphalt concrete meeting the requirements of Asphalt Shim Course F9 or 9.5 F3 Top Course. Tack coat meeting the requirements of Materials Designation 407.0102 Asphalt Emulsion Diluted Tack Coat shall be used to adhere the rumble strip to the existing pavement. Temporary rumble strips shall be formed using a specially constructed rumble strip paver (drag box) pulled transversely across the pavement, or by hand placement between forms fixed to the pavement. If forms are used, they shall be removed prior to compaction of the asphalt mixture. Compaction shall be accomplished using a plate tamper or a static roller.

The roadway surface on which the rumble strips are to be attached shall be dry, free of surface contaminants such as dust or oil, and shall be 45°F or greater unless otherwise authorized by the Engineer or Authorized User Representative. The pavement surface shall be cleaned with compressed air just prior to tack coating and subsequent installation of rumble strips.

LOT 3: COLD RECYCLING (Cont'd)

Temporary rumble strips shall be placed in a succession of three 6 Strip Patterns according to the attached “Suggested Layout Details - Temporary Rumble Strips”. Each strip shall be placed on 10-foot centers and traversing the full width of each travel lane. On curbed roadways, rumble strips shall end a minimum of 3-feet from the curb so as to not interfere with drainage. Rumble strips shall be between 6-inches and 9-inches in width and have a final compacted thickness of 0.4 inches + 0.1 inches.

Any raised rumble strips that fail to adhere to the pavement, or become damaged or flattened such that, in the opinion of the Engineer or Authorized User Representative, they are no longer performing their intended function, shall be replaced or repaired by the Contractor to the satisfaction of the Engineer or Authorized User Representative. Any associated damage to the pavement shall also be repaired by the Contractor to the satisfaction of the Engineer or Authorized User Representative. These replacements or repairs shall be made at no additional expense to the Authorized User. When directed by the Engineer or Authorized User Representative, (e.g., prior to the start of the winter plowing season), or prior to the placement of successive pavement courses, the Contractor shall completely remove the rumble strips from the pavement. Rumble strips shall be removed upon completion of work and concurrently with the removal of other temporary traffic control signs and devices. Any pavement that is damaged in the process of removing the rumble strips shall be repaired by the Contractor to the satisfaction of the Engineer or Authorized User Representative at no additional expense to the Authorized User.

**c. Basis of Payment**

All costs for the installation, maintenance and removal of temporary rumble strips are included in the price bid per linear foot of rumble strip.

**d. Suggested Layout Details Drawing-- Temporary Rumble Strips**

See the Suggested Layout Details Drawing in the next page.

**3.15 Detailed Specifications – Cold Recycling Asphalt Concrete**

Please, see Attachment 11 - *Detailed Specifications – Liquid Bituminous Materials*.

LOT 3: COLD RECYCLING (Cont'd)

Suggested Layout Details -- Temporary Rumble Strips

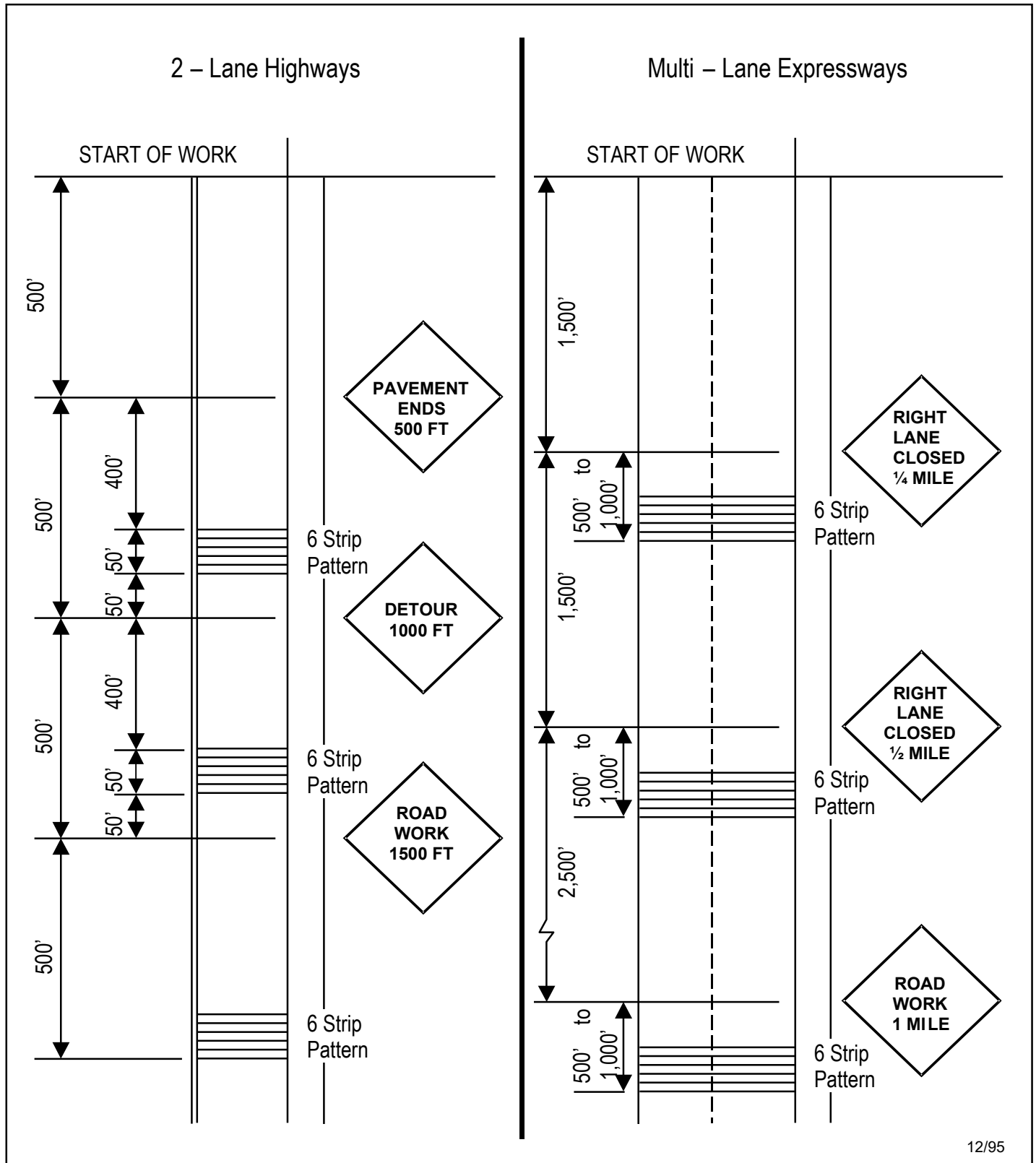

## LOT 4: HEATER SCARIFICATION

### 4.1 Introduction

Heater scarification is a continuous multi-step process in which the existing asphalt pavement surface is recycled using specialized equipment. The asphalt pavement surface is heated causing the asphalt to soften. The softened asphalt surface is then immediately scarified and milled to a specified depth. The reclaimed asphalt pavement is then mixed with a recycling agent that rejuvenates the asphalt. The recycled mix is then placed and compacted back onto the roadway. A new bituminous concrete sealing layer is added later. Existing cracks are eliminated, and the resulting pavement should provide a longer life.

### 4.2 Pricing Information

#### 4.2.1 General

Price quoted shall be to three (3) decimal places.

Price quoted shall be F.O.B. the Contractor's location per square yard for the pavement heater scarified, and F.O.B. the Contractor's location per pound for the recycling agent.

Heater scarification shall be performed in accordance with NYSDOT's Standard Specifications. Cleaning and preparing the existing pavement will be the responsibility of the Authorized User. Erecting warning signs and directing traffic will be the responsibility of the Authorized User or the Contractor using the optional work zone traffic control section at the discretion of the Authorized User.

Price quoted for heating, hauling, and applying the recycling agent from Contractor's location to project location shall be net per pound of recycling agent.

Price quoted for mobilization from Contractor's location to project location shall be net per square yard of accepted heater scarification performed at the locations indicated by the Authorized User.

Price quoted for Optional Work Zone Traffic Control shall be per square yard of heater scarification.

Price quoted for additional flaggers (if required) shall be net per day (to the nearest quarter day) for additional flaggers.

Price quoted for optional pilot vehicles with drivers (if required) shall be net per day (to the nearest quarter day) for each pilot vehicle with driver.

#### 4.2.2 Insurance

Please refer to Section 6.19 - Insurance of the Invitation for Bids for information about insurance.

### 4.3 Asphalt Price Adjustments – Heater Scarification

#### 4.3.1 General

- a. Asphalt price adjustments allowed will be based on the November 1, 2025 average of the F.O.B. terminal price per ton of unmodified PG 64S-22 binder without anti-stripping agent (base average F.O.B. terminal price). The new monthly average terminal price will be determined by the New York State Department of Transportation based on prices of pre-approved primary sources of performance graded binder in accordance with the New York State Department of Transportation Standard Specification.

**The November 1, 2025 average is \$638.000**

**NOTE:** The same grade of asphalt cement used in establishing the base average F.O.B. terminal price shall be used in establishing the new average F.O.B. terminal price.

In the event that one or more of the New York State Department of Transportation pre-approved sources discontinue posting a price for asphalt cement, the base average F.O.B. terminal **price shall not be recalculated.**

- b. The new average F.O.B. terminal price will be determined based on the above F.O.B. terminal prices posted each month during the contract period. However, asphalt price adjustments, in accordance with the formula below, will be effective for deliveries made on and after the first of the month following the adjustment date.

LOT 4: HEATER SCARIFICATION (Cont'd)

- c. The unit prices of bituminous materials purchased from any award based on this specification will be subject to adjustment based on the following formula:

$$\begin{array}{|c|} \hline \text{Price} \\ \text{Adjustment} \\ \text{(per pound)} \\ \hline \end{array} = \frac{\begin{array}{|c|} \hline \text{New Monthly Average} \\ \text{FOB Terminal Price} \\ \hline \end{array} - \begin{array}{|c|} \hline \text{Base Average} \\ \text{Terminal Price} \\ \hline \end{array}}{2000} \times \begin{array}{|c|} \hline \text{Total} \\ \text{Allowable} \\ \text{Petroleum \%} \\ \hline \end{array}$$

Positive Price Adjustment number shall be added to original per pound Bid Price.

Negative Price Adjustment number shall be subtracted from original per pound Bid Price.

**New Monthly Average F.O.B. Terminal Price**

The average F.O.B. terminal price for unmodified PG 64S-22 binder without anti-stripping agent is as determined by the New York State Department of Transportation per New York State Department of Transportation Standard Specification.

**Base Average F.O.B. Terminal Price**

The average F.O.B. terminal price of unmodified PG 64S-22 binder without anti-stripping agent is as determined by the New York State Department of Transportation as of November 1, 2025.

**Total Allowable Petroleum**

The percentage of total allowable petroleum for each item is as follows:

Item	Material Designation	Asphalt %	Petroleum Allowance %	Total Allowable Petroleum %
417.0101	Recycling Agent	65.0	1.0	66.0%

Asphalt Price Adjustments will not be allowed for materials which do not have an asphalt cement base.

- d. Work performed after the expiration of the contract, where no extension has been granted, resultant from purchase orders placed prior to expiration of the contract will be based on the new average for the month in which the work is done applying the same base established for that contract.
- Asphalt Price Adjustments for any contracts that are extended will be based on the new average for the month in which the work is done applying the same base established for that contract.
- e. Asphalt Price Adjustments allowed by this contract shall be calculated and applied to the original prices. There will not be Asphalt Price Adjustments unless the change amounts to more than \$0.001 per pound from the original price. In these instances, prices will revert back to the original prices.
- f. All Asphalt Price Adjustments will be computed to three decimal places.
- g. Should these provisions result in a price structure which becomes unworkable, detrimental or injurious to the State or in prices which are not truly reflective of market conditions or which are deemed by the Commissioner to be unreasonable or excessive, and no adjustment in price is mutually agreeable, the Commissioner reserves the sole right upon ten days written notice mailed to the Contractor to terminate any contract resulting from this bid opening.
- h. All Asphalt Price Adjustments shall be published by the State and issued to all contract holders whose responsibility will be to attach the appropriate State notification (based on when the work was performed) to the payment invoice submitted to the Authorized User.

**LOT 4: HEATER SCARIFICATION (Cont'd)**

**4.3.2 Asphalt Price Adjustment – Heater Scarification: Example**

This example is for illustration purposes only. Actual Base Average Price, etc., may vary.

Material Designation 417.0101

Base Average Price = \$638.000

New Average Price = \$648.000

% Total Allowable Petroleum = 66%

$$\begin{array}{c}
 \boxed{\begin{array}{c} \text{Price} \\ \text{Adjustment} \\ \text{(per pound)} \end{array}} = \boxed{\frac{(648.000 - 638.000)}{2000}} \times \boxed{0.66} \\
 \\
 \boxed{\begin{array}{c} \text{Price} \\ \text{Adjustment} \\ \text{(per pound)} \end{array}} = \boxed{+\$0.003 \text{ per pound}}
 \end{array}$$

Positive Price Adjustment number shall be added to original per pound Bid Price.

Negative Price Adjustment number shall be subtracted from original per pound Bid Price.

**4.4 Minimum Project Size**

The minimum project size for Heater Scarification under this contract shall be 10,000 square yards. This is approximately 0.85 miles of two-lane highway at 20-feet wide. First quantity/price change occurs at 20,000 which is approximately 1.7 miles of a 2-lane highway at 20-feet wide. A second quantity/price change occurs at 50,000 which is approximately 4.2 miles of a 2-lane highway at 20-feet wide.

**4.5 Payment**

Payment for Heater Scarification of Asphalt Concrete shall be made at the contract price per unit bid for the actual number of square yards of pavement heater scarified and the actual number of pounds of recycling agent at 60°F verified by the Authorized User and used in the accepted portion of the work. The determination as to quantities involved in any contract shall be accepted as final and binding upon the Contractor.

A delivery slip stating quantities of recycling agent shall accompany each shipment. An invoice listing the quantities of heater scarification and recycling agent shall be sent promptly by the Contractor to the Engineer or Authorized User Representative.

Payment for optional work zone traffic control (if required) will be made based on the number of square yards of completed recycling.

Payment for additional flaggers (if required) will be made based on the number of days (computed to the nearest quarter day) that additional flaggers are utilized as directed by the Engineer or Authorized User Representative.

Payment for optional pilot vehicles with drivers will be made based on the number of days (computed to the nearest quarter day) that optional pilot vehicles with drivers are utilized as directed by the Engineer or Authorized User Representative.

The price per unit arrived at (mutually estimated) by the Contractor and the Authorized User on the Price Calculation Worksheet or the price per unit resultant from the quick quote process (whichever is applicable) shall be the price per unit paid to the Contractor. The quantity of recycling agent shall be considered binding upon the Contractor.

**4.6 Payment for Mobilization from Contractor’s Equipment Storage Facility to Project Location**

Payment for mobilization from Contractor’s equipment storage facility shall be made based on the actual number of accepted square yards of heater scarification at the locations indicated by the State’s Resident Engineer or Authorized User Representative at the contract price for mobilization from Contractor’s equipment storage facility to project location per square yard of heater scarification for the appropriate distance and quantity range.

## LOT 4: HEATER SCARIFICATION (Cont'd)

### **4.7 Payment to Heat, Haul, and Apply Recycling Agent from Contractor's Bituminous Storage Facility to Project Location**

Payment for heating, hauling and applying the recycling agent from Contractor's bituminous storage facility to project location shall be made for actual number of pounds of recycling agent at 60°F at the appropriate price bid for the actual distance to the project verified by the Authorized User Representative and used in the accepted portion of the work.

### **4.8 Pre-Heater Scarification Meeting**

The Contractor shall schedule a Pre-Heater Scarification Meeting with the affected Resident Engineer or Authorized User Representative after the acceptance of the Contractor's quotation by the Authorized User and at least one week prior to the start of the heater scarification. Project-level supervisors for both the Authorized User and the Contractor will be present at this meeting. At this meeting the Contractor shall present Certificates of Insurance evidencing compliance with the additional insurance requirements, their proposed heater scarification schedule, procedure, and Traffic Control Plan (if applicable) to the Authorized User Representative for approval. Prior to the start of heater scarification, the Contractor shall coordinate the details of the heater scarification with the Resident Engineer or Authorized User Representative.

### **4.9 Supervision**

The Authorized User shall provide supervision for the heater scarification operation. The Resident Engineer or Authorized User Representative shall designate a heater scarification supervisor, and that person shall be in charge of and responsible for the operation. The following portions of Section 105 - CONTROL OF WORK of the Standard Specifications shall apply to these projects: 105-01 ENGINEER'S AUTHORITY, 105-05 VENDOR RESPONSIBILITY, 105-06 COOPERATION WITH UTILITIES AND OTHER CONTRACTORS."

### **4.10 Work Hours**

Work will not be permitted on Sundays and Holidays. If the Contractor desires to work overtime on other days, dispensation from the NYS Labor Department must be obtained using Department of Labor Form PW-30.

### **4.11 Mix Design**

The Contractor will core the pavement and develop the entire mix design including specifying the amount of recycling agent to properly recycle the pavement.

#### **4.11.1 Mix Design for NYS Department of Transportation (NYSDOT)**

After a Contractor receives a verbal or written request for taking cores for mix design for a specific pavement section from the NYSDOT, the Contractor must supply a mix design for approval to the NYSDOT Director of Materials Bureau within 15 workdays unless additional time is granted by the Resident Engineer. Copies shall be sent to the Resident Engineer and the Director of Materials Bureau. The contact information shall be supplied to the Contractor by the Resident Engineer. Core holes drilled by the Contractor to derive information for a mix design must be filled the day drilled with cold mix bituminous concrete approved by the Resident Engineer. Traffic control for the coring operation shall be performed by the Contractor with prior approval of the lane closure scheme by the Resident Engineer.

#### **4.11.2 Mix Design for Authorized Users other than NYSDOT**

After a Contractor receives a verbal or written request for taking cores for mix design for a specific pavement section from an Authorized User other than NYSDOT, the Contractor must supply a mix design for approval to the Authorized User Representative within 15 workdays unless additional time is granted by the Authorized User Representative. Copies shall be sent to the Authorized User Representative or their designee. The contact information shall be supplied to the Contractor by the Authorized User Representative. Core holes drilled by the Contractor to derive information for a mix design must be filled the day drilled with cold mix bituminous concrete approved by the Authorized User Representative. Traffic control for the coring operation shall be performed by the Contractor with prior approval of the lane closure scheme by the Authorized User Representative.

### **4.12 Restoration of Disturbed Areas**

During the course of the work, the Contractor shall take reasonable care not to disturb areas outside the existing pavement. Any areas disturbed by the Contractor shall be returned to their original condition at no expense to the owner. Any and all debris generated as part of the work shall be removed by the Contractor upon completion of the project.

---

**LOT 4: HEATER SCARIFICATION (Cont'd)**

**4.13 Damaged or Deficient Areas**

Prior to acceptance and payment for the heater scarification by the Authorized User, any mixture that ravels, delaminates, streaks, fails to properly cure, or is in anyway defective shall be redone to the satisfaction of the Resident Engineer or Authorized User Representative at the Contractor's expense.

**4.14 Optional Work Zone Traffic Control**

The Contractor shall submit a per square yard price for work zone traffic control as prescribed by this specification. Contractor is responsible for work zone traffic control during coring operations with no additional cost to the Authorized User whether or not optional work zone traffic control is included in the quick quote form.

If optional work zone traffic control is included in the quick quoting process, the Contractor shall be responsible for Work Zone Traffic Control. Traffic shall be controlled in accordance with the Manual of Uniform Traffic Control Devices (MUTCD) and Sections 619-1 through 619-3 of the Standard Specifications including modifications to the Standard Specifications. The Contractor shall submit a Work Zone Traffic Control Plan for approval to the Resident Engineer at the Pre-Heater Scarification Meeting. For two-way roadways, NYSDOT 619 Standard Sheets 619-307, 619-308, 619-309, 619-312 and 619-314 may be used as a basis for development of a Work Zone Traffic Control Plan. For one-way roadways, NYSDOT 619 Standard Sheets 619-302, 619-303, and 619-313 may be used as a basis for development of a Work Zone Traffic Control Plan. For one-way Freeways or Expressways, NYSDOT 619 Standard Sheets 619-301, 619-302, 619-304, and 619-305 may be used as a basis for development of a Work Zone Traffic Control Plan. A link to NYSDOT 619 Standard Sheets can be found on Attachment 14 – *NYSDOT Work Zone Traffic Control* included within this Invitation for Bids.

All necessary flaggers for traffic control shall be provided by the Contractor. A minimum of three flaggers shall be provided while the recycling operation is underway. One shall be stationed at each end of the operation, and one shall be stationed with the milling machine/paver. The Contractor shall station flaggers such that communication is maintained between the flaggers. Hand signals, radios, pilot vehicles, or some other means of communication may be used subject to the approval of the Resident Engineer or Authorized User Representative.

LOT 4: HEATER SCARIFICATION (Cont'd)

The Contractor shall provide construction signs as specified in Section 619-1 through 619-3 of the Standard Specifications and in the MUTCD. At a minimum the Contractor shall install the following permanent construction signs:

Sign	Minimum Size	Location
ROAD WORK NEXT _____ MILES	<u>G20-1</u> Conventional 36" x 18"  Freeways 48" x 24"	On main line upstream of project in each direction.
END ROAD WORK	<u>G20-2</u> Conventional 36" x 18"  Freeways 48" x 24"	On main line after end of project in each direction.
ROAD WORK AHEAD	<u>W20-1</u> Conventional 36" x 36"  Freeways 48" x 48"	On main line in advance of the affected highway segment in each direction and on major intersecting roads 300-500 feet in advance of main line. Sign should be covered if it conflicts with temporary signing in the vicinity. (Place between the G20-1 and the first warning sign that states condition - i.e. W8-12, W8-9 or W8-15).
DO NOT PASS	<u>R4-1</u> Conventional 24" x 30"	If 2' x 4" temporary yellow markings are used instead of full barrier centerline pavement markings, place the first sign at or within 100-feet of the beginning of the unmarked area, second within 1,000-feet and subsequent signs, spaced every ½ mile along project in each direction.
NO CENTER LINE	<u>W8-12</u> Conventional 36" x 36"	If 2' x 4" temporary yellow markings are used instead of full barrier centerline pavement markings, place the first sign in advance of the condition and the first "DO NOT PASS" sign: 300' urban is preferred (100' minimum), 500' rural is preferred (200' minimum). Place additional signs spaced every 2 miles on mainline in each direction and after every major intersecting road.
LOW SHOULDER	<u>W8-9</u> Conventional 36" x 36"  Freeways 48" x 48"	Place on mainline spaced every 2 miles along project in each direction and after every major intersecting road until shoulder back-up is installed (if conditions warrant use, place between the W8-12 and R4-1, maintaining a minimum of 200' between signs for rural roads and 100' on urban. The W8-12 can be moved upstream to accommodate the required spacing.)
GROOVED PAVEMENT	<u>W8-15</u> Conventional 36" x 36"  Freeways 48" x 48"	On any roadway 500-feet in advance of rebates milled under this contract but not paved. Remove or cover after paving rebate.

\*\*All signs should maintain an absolute minimum spacing of 200' rural or 100' urban. 500' is preferred on rural and 300' is preferred on urban. Double stacking of any of the above signs, or combination thereof, will NOT be permitted.

## LOT 4: HEATER SCARIFICATION (Cont'd)

Major intersecting roads are defined as State, County, Town, Village, or City roads. The Contractor may provide portable signs as shown in Figure 6F-2 of the MUTCD and meeting the requirements of Section 619 of the Standard Specifications for lane closures during work hours.

With prior permission of the State's Resident Engineer or Authorized User Representative, the Contractor may provide portable signs as shown in Figure 6F-2 of the MUTCD for the above referenced DO NOT PASS and NO CENTER LINE signs. Signs left active at night shall be rigid and reflectorized in accordance with the Standard Specifications. The Contractor shall be responsible for assuring that these signs will be in their upright, visible positions twenty-four hours a day, seven days a week while 2' x 4" temporary yellow markings are used instead of full barrier pavement markings.

### 4.14.1 Special Note - Temporary Pavement Markings

The Contractor shall install and maintain temporary pavement markings on any paved surface without permanent pavement markings before opening it to traffic, before nightfall or before the end of the workday, whichever comes soonest except for areas that are open during the work shift with channelizing devices or flaggers. Temporary pavement markings shall meet the requirements of Section 619 of the Standard Specifications except that two-lane, two-way highways may be left without full barrier centerlines in no passing zones for a maximum of 7 calendar days provided that NO CENTER LINE (W8-12, black on orange), NO PASSING ZONE (W14-3, black on orange pennant shaped sign), and DO NOT PASS (R4-1) signs are used consistent with the MUTCD and in conjunction with yellow 2-foot by 4-inch temporary markings consisting of retro-reflective removable pavement marking tape, paint, or yellow temporary overlay markers installed on a 40-foot cycle to delineate the centerline location.

The Authorized User is responsible for the final pavement markings unless otherwise indicated in the contract. If the Contractor chooses to install NO CENTER LINE and DO NOT PASS signs and temporary yellow 2-foot by 4-inch pavement markings in lieu of full barrier centerline markings, the signs shall be left in place until the Authorized User has completed installing the final pavement markings. The Authorized User will normally complete final pavement markings within 7 days of the project completion. However, if unavoidable situations delay the pavement marking installation the signs shall remain in place for 14 calendar days after the project has been completed or until the Authorized User has completed installing the final pavement markings, whichever comes first. If permanent pavement marking cannot be installed within 14 days of the project completion, Authorized User must install interim pavement marking including center lines, edge lines, stop bars, and simple crosswalks with no hatching before the end of 14 days after project completion.

All costs for Work Zone Traffic Control including flagging, temporary pavement markings, delineation, and construction signs are to be included in the prices bid per square yard for optional work zone traffic control. No separate payment shall be made.

### 4.14.2 Additional Flaggers for Work Zone Traffic Control

If the Engineer or Authorized User Representative determines that more than 3 flaggers are necessary to properly control traffic on two-way roadways or more than 2 flaggers are necessary to properly control traffic on one-way roadways and the Contractor is responsible for Work Zone Traffic Control under this Invitation for Bids, the Contractor shall provide additional flaggers under the Additional Flaggers item. The price bid per flagger per day shall include all costs of providing a flagger where directed by the Engineer or Authorized User Representative with all the necessary safety equipment, i.e., stop/slow paddle, flag, vest, hardhat, etc. Payment shall be by the day for each flagger provided. A day shall be determined as including the time period between the commencement and completion of work on any calendar day. No extra payment shall be provided if the Contractor elects to work a longer day than the standard eight-hour workday. Payment shall be made to the nearest quarter day as determined by the Engineer or Authorized User Representative.

**LOT 4: HEATER SCARIFICATION (Cont'd)**

**4.14.3 Pilot Vehicles with Drivers**

The Contractor shall provide sufficient two-way radio equipped pilot vehicles with drivers to guide traffic around the Heater Scarification work zone at a maximum of 20 miles per hour. Payment shall be by the day for each pilot vehicle with driver provided. A day shall be determined as including the time period between the commencement and completion of work on any calendar day. No extra payment shall be provided if the Contractor elects to work a longer day than the standard eight-hour workday. Payment shall be made to the nearest quarter day as determined by the Engineer or Authorized User Representative. The pilot vehicle(s) shall be equipped with construction signs meeting the requirements of Section 6F.58 of the MUTCD and a rotating amber beacon:

Sign	Minimum Size	Location
PILOT CAR FOLLOW ME	G20-4 36" X 18"	ON BACK OF PILOT VEHICLES.

The pilot vehicle shall have the name of the Contractor prominently displayed.

**4.14.4 Work Zone Traffic Intrusion Initiative**

**(Attention - Special Note)** As part of the Department of Transportation’s Work Zone Intrusion Initiative, the following countermeasures shall be applied to Heater Scarification Projects in this Invitation for Bids if the Contractor is responsible for Optional Work Zone Traffic Control:

**Channelizing Device Spacing Reduction**

A maximum channelizing device spacing of 40-feet shall be provided at stationary work sites where workers are exposed to traffic. This spacing shall be maintained a reasonable distance upstream of workers and shall be used throughout the work zone.

Where tapers are located less than 500-feet from the work site the 40-foot spacing shall be used in the taper as well.

Drums or vertical panels are preferred for long-term and intermediate-term work zones, and at any locations where the risk of intrusion is high. Traffic cones are normally adequate for work zones set up and removed on a daily basis.

In long lane or shoulder closures, at least two channelizing devices shall be placed transversely at maximum 800-foot intervals to discourage traffic from driving through the closed lane. **Transversely placed devices are not required where pilot cars are in use.**

Frequent checks shall be made to reset channelizing devices dislodged by traffic.

**Flagger Station Enhanced Setups**

Additional cones and a flag tree meeting the requirements of Section 6F.62 of the MUTCD shall be used upstream of flagger stations to provide added warning to drivers. These devices shall be used for flagger stations except those that are constantly moving or are in use at one location for no more than a few minutes. If the W20-7a Flagger sign is used, the additional cones and flag tree shall also be used.

For additional details on Flagger Station Enhanced Setups, see Attachment 14 – *NYS DOT Work Zone Traffic Control* included in this Invitation for Bids.

**4.15 Detailed Specifications – Heater Scarification**

Please, see Attachment 11 - *Detailed Specifications – Liquid Bituminous Materials*.

## LOT 5: MICRO-SURFACING AND/OR QUICK SET SLURRY SEAL

### 5.1 Introduction

Micro-surfacing is a pavement preventive maintenance treatment which offers minor improvements to rideability and has excellent friction characteristics. Quick Set Slurry Seal is a pavement preventive maintenance treatment that offers minor improvements to rideability and has excellent friction characteristics for low volume roads.

### 5.2 Pricing Information

#### 5.2.1 General

Price quoted shall be to three (3) decimal places.

Price quoted with the exception of “Price Additionals” shall be net per ton furnished, hauled, delivered, and applied with Contractor’s equipment at the locations indicated by the Resident Engineer, or Authorized User Representative and must include material costs. Micro-surfacing shall be applied in accordance with NYSDOT’s Standard Specifications and as per the attached specification for Micro-surfacing. Quick set slurry seal shall be applied in accordance with NYSDOT’s Standard Specifications and as per the attached material specification for quick set slurry seal. Cleaning and preparing the existing pavement will be the responsibility of the Authorized User. Erecting warning signs and directing traffic will be the responsibility of the Authorized User or the Contractor using the optional Work Zone Traffic Control section at the discretion of the Authorized User.

#### **Price Additionals:**

#### **Optional Work Zone Traffic Control Outside of New York City and Nassau, Rockland and Westchester Counties**

Price quoted for additional cost per ton for optional work zone traffic control shall be net per ton of completed Micro-surfacing and/or quick set slurry seal placed. This price shall include all costs to properly control traffic in accordance with these specifications.

#### **Optional Work Zone Traffic Control within New York City, Nassau, Rockland, Suffolk, and Westchester Counties**

Price quoted for additional cost per ton for optional work zone traffic control in the five boroughs of New York City and the counties of Nassau, Rockland, Suffolk, and Westchester shall be net per ton of completed Micro-surfacing and/or quick set slurry seal placed therein. This price shall include all costs to properly control traffic in accordance with these specifications. This price is an additional price (on top of the basic price for work zone traffic control) for work zone traffic control in the five boroughs of New York City and the counties of Nassau, Rockland, Suffolk, and Westchester.

#### **Night Work**

Price quoted for additional cost per day of night work shall be net cost per day when directed by the Engineer or Authorized User Representative.

#### **Weekends**

Price quoted for additional cost per day for Saturday and Sunday work, when directed by the Resident Engineer or Authorized User Representative, shall be net per day for Saturday or Sunday work. When requested to work on Saturday and/or Sunday by the Resident Engineer or Authorized User Representative, the Contractor shall be paid the price bid for Saturday and/or Sunday work, as appropriate. The price bid per day shall include the cost of all premium labor charges. The Contractor shall only be due the extra payment when work on Saturday and/or Sunday is in the best interest of the Authorized User. Work done by the Contractor on Saturday and/or Sunday for their own convenience or to make up for rain outs shall not result in extra payment for Saturday and/or Sunday work.

#### **Micro-surfacing and/or Quick Set Slurry Seal within the Five Boroughs of New York City**

Price quoted for additional cost per ton for Micro-surfacing and/or quick set slurry seal within the five boroughs of New York City shall be net per ton of completed Micro-surfacing and/or quick set slurry seal placed therein. This price is an additional price (on top of the basic price per ton of Micro-surfacing and/or quick set slurry seal) for Micro-surfacing and/or quick set slurry seal placed in the five boroughs of New York City.

LOT 5: MICRO-SURFACING AND/OR QUICK SET SLURRY SEAL (Cont'd)

**Additional Flaggers**

Price quoted for additional flaggers (if required) shall be net per day (to the nearest quarter day) for additional flaggers.

**Pilot Vehicle with Driver**

Price quoted for optional pilot vehicles with drivers (if required) shall be net per day (to the nearest quarter day) for each pilot vehicle with driver.

**Additional Construction Signs**

Price quoted for optional additional construction signs shall be net per square foot (including signs, sign supports, installation, and removal) of additional construction signs.

**Abrading Existing Pavement Markings, Work Zone Traffic Control by Authorized User**

Price quoted for abrading the existing pavement markings by the Contractor, with work zone traffic control by the Authorized User (if required) shall be net per linear foot at 4-inches wide of pavement markings actually abraded by the Contractor. This price shall include all costs for pavement marking abrading including all labor, materials, and equipment necessary to abrade the pavement markings.

**Abrading Existing Pavement Markings, Work Zone Traffic Control by Contractor**

Price quoted for abrading the existing pavement markings by the Contractor, with work zone traffic control by the Contractor (if required) shall be net per linear foot at 4-inches wide of pavement markings actually abraded by the Contractor. This price shall include all costs for pavement marking abrading including all labor, materials, and equipment necessary to abrade the pavement markings and all costs to properly control traffic.

**Milling Recesses to Receive Pavement Markings, Work Zone Traffic Control by Authorized User**

Price quoted for milling recesses to receive pavement markings. Price shall be net per linear foot milled.

**Milling Recesses to Receive Pavement Markings, Work Zone Traffic Control by Contractor**

Price quoted for milling recesses to receive pavement markings. Price shall be net per linear foot milled.

**Longitudinal Joint Repair**

Price quoted for additional cost per ton for longitudinal joint repair shall be net per ton of Micro-surfacing placed.

**Notes/Additional Information**

The price (mile and ton range) for a specific job will be calculated at the same rate. The rate will be determined by finding the one category which applies to the total mile(s) and tons per job. For example, a job which is 15 miles from the plant will be calculated at the same rate per ton for each mile (from 11 to 25) which is indicated in the 11-25 miles column herein, rather than on a cumulative basis. Similarly, a job that has a total requirement of 450 tons and takes 3 days to complete would be calculated using the rate for 150 tons per day which is indicated in the 101-300 tons column since it would be presumed that equal quantities would be applied each day.

**Contractors who do not bid a haul, deliver and apply price are not permitted under this award to offer haul and apply prices to agencies, political subdivisions, or others authorized by law to use Subject Award.**

**5.2.2 Insurance**

Please refer to Section 6.19 - Insurance of the Invitation for Bids for information about insurance.

**LOT 5: MICRO-SURFACING AND/OR QUICK SET SLURRY SEAL (Cont'd)**

**5.3 Asphalt Price Adjustments – Micro-surfacing and/or Quick Set Slurry Seal**

**5.3.1 General**

- a. Asphalt price adjustments allowed will be based on the November 1, 2025 average of the F.O.B. terminal price per ton of unmodified PG 64S-22 binder without anti-stripping agent (base average F.O.B. terminal price). The new monthly average terminal price will be determined by the New York State Department of Transportation based on prices of pre-approved primary sources of performance graded binder in accordance with the New York State Department of Transportation Standard Specification.

**The November 1, 2025 average is \$638.00**

**NOTE:** The same grade of asphalt cement used in establishing the base average F.O.B. terminal price shall be used in establishing the new average F.O.B. terminal price.

In the event that one or more of the New York State Department of Transportation pre-approved sources discontinue posting a price for asphalt cement, the base average F.O.B. terminal **price shall not be recalculated.**

- b. The new average F.O.B. terminal price will be determined based on the above F.O.B. terminal prices posted each month during the contract period. However, asphalt price adjustments, in accordance with the formula below, will be effective for deliveries made on and after the first of the month following the adjustment date.
- c. The unit prices of bituminous materials purchased from any award based on this specification will be subject to adjustment based on the following formula:

Price Adjustment (Per Ton)	=	$\left( \begin{array}{c} \text{New Monthly Average} \\ \text{F.O.B. Terminal Price} \end{array} - \begin{array}{c} \text{Base Average F.O.B.} \\ \text{Terminal Price} \end{array} \right)$	X	Total Allowable Petroleum %
-------------------------------	---	---	---	-----------------------------------

Positive Price Adjustment number shall be added to original per ton Bid Price.

Negative Price Adjustment number shall be subtracted from original per ton Bid Price.

**New Monthly Average F.O.B. Terminal Price**

The average F.O.B. terminal price for unmodified PG 64S-22 binder without anti-stripping agent is as determined by the New York State Department of Transportation per New York State Department of Transportation Standard Specification.

**Base Average F.O.B. Terminal Price**

The average F.O.B. terminal price of unmodified PG 64S-22 binder without anti-stripping agent is as determined by the New York State Department of Transportation as of November 1, 2025.

LOT 5: MICRO-SURFACING AND/OR QUICK SET SLURRY SEAL (Cont'd)

**Total Allowable Petroleum**

The percentage of total allowable petroleum for each item is as follows:

Item #	Material Designation	Asphalt %	Petroleum Allowance %	Total Allowable Petroleum %
413.02010118	Micro-surfacing, Type II, F1	9.0	0.2	9.2
413.02020118	Micro-surfacing, Type II, F2	9.0	0.2	9.2
413.02030118	Micro-surfacing, Type II, F3	9.0	0.2	9.2
413.03010118	Micro-surfacing, Type III, F1	7.5	0.2	7.7
413.03020118	Micro-surfacing, Type III, F2	7.5	0.2	7.7
413.03030118	Micro-surfacing, Type III, F3	7.5	0.2	7.7
413.04030118	Micro-surfacing, Type III Rut Filling	7.5	0.2	7.7
414.02030118	Quick-set Slurry, Type II	13.5	0.2	13.7
414.03030118	Quick-set Slurry, Type III	12.0	0.2	12.2

Asphalt Price Adjustments will not be allowed for materials which do not have an asphalt cement base.

- d. Work performed after the expiration of the contract, where no extension has been granted, resultant from purchase orders placed prior to expiration of the contract will be based on the new average for the month in which the work is done applying the same base established for that contract.

Asphalt Price Adjustments for any contracts that are extended will be based on the new average for the month in which the work is done applying the same base established for that contract.

- e. Asphalt Price Adjustments allowed by this contract shall be calculated and applied to the original prices. There will not be Asphalt Price Adjustments unless the change amounts to more than \$0.10 per ton from the original price. In these instances, prices will revert back to the original prices.
- f. All Asphalt Price Adjustments will be computed to three decimal places.
- g. Should these provisions result in a price structure which becomes unworkable, detrimental or injurious to the State or in prices which are not truly reflective of market conditions or which are deemed by the Commissioner to be unreasonable or excessive, and no adjustment in price is mutually agreeable, the Commissioner reserves the sole right upon ten days written notice mailed to the Contractor to terminate any contract resulting from this bid opening.
- h. All Asphalt Price Adjustments shall be published by the State and issued to all contract holders whose responsibility will be to attach the appropriate State notification (based on when the work was performed) to the payment invoice submitted to the Authorized User.

**LOT 5: MICRO-SURFACING AND/OR QUICK SET SLURRY SEAL (Cont'd)**

**5.3.2 Asphalt Price Adjustment – Micro-surfacing and/or Quick Set Slurry Seal: Example**

This example is for illustration purposes only. Actual Base Average Price, etc., may vary.

Material Designation: 413.02010118

Base Average Price = \$638.000

New Average Price = \$648.000

% Total Allowable Petroleum = 9.2%

$$\begin{array}{|c|} \hline \text{Price} \\ \text{Adjustment} \\ \text{(per ton)} \\ \hline \end{array} = \begin{array}{|c|} \hline (648.000 - 638.000) \\ \hline \end{array} \times \begin{array}{|c|} \hline 0.092 \\ \hline \end{array}$$

$$\begin{array}{|c|} \hline \text{Price} \\ \text{Adjustment} \\ \text{(per ton)} \\ \hline \end{array} = \begin{array}{|c|} \hline +\$0.920 \text{ per ton} \\ \hline \end{array}$$

Positive Price Adjustment number shall be added to original per ton Bid Price.

Negative Price Adjustment number shall be subtracted from original per ton Bid Price.

**5.4 Delivery Ticket**

A delivery ticket shall be provided with each load of bituminous asphalt emulsions stating the following:

1. Storage facility identification
2. Ticket Number
3. Date/time
4. Item Number and Type
5. Quantity ticket printed by machine
6. Quantity in 60°F gallons for emulsions

**5.5 Payment**

Payment for Micro-Surfacing Types II, and III, Quick Set Slurry Seal types II and III; and Rut Filling shall be made at the contract price per ton for the actual total number of tons of aggregate, mineral filler, and asphalt emulsion verified by the Authorized User and used in the accepted portion of the work. An invoice shall be sent promptly by the Contractor to the Resident Engineer of the region or to the Authorized User Representative placing the order.

The price per unit arrived at (mutually estimated) by the Contractor and the Authorized User on the Price Calculation Worksheet or the price per unit resultant from the actual average daily production, whichever is less, shall be the price per unit paid to the Contractor. No additional payment shall be due to the Contractor for production rates that are not equal to the rate upon which the calculation work sheet price was based.

Payment for optional work zone traffic control (if required) will be made based on the number of tons of completed Micro-surfacing and/or quick set slurry seal for the applicable type of highway and quantity range. Payment for optional work zone traffic control in the five boroughs of New York City and the counties of Nassau, Rockland, Suffolk, and Westchester (if required) will be made based on the number of tons of completed Micro-surfacing and/or quick set slurry seal for the applicable type of highway and quantity range. This payment is an additional payment (on top of the basic payment for work zone traffic control) for work zone traffic control therein.

Payment for night work will be based on the actual number of days (nights) worked at the direction of the Resident Engineer or Authorized User Representative.

## LOT 5: MICRO-SURFACING AND/OR QUICK SET SLURRY SEAL (Cont'd)

Payment for work on Saturday and/or Sunday will be based on the actual number of days worked at the direction of the Resident Engineer or Authorized User Representative.

Payment for Micro-surfacing and/or quick set slurry seal placed in the five boroughs of New York City will be made based on the actual number of tons of completed Micro-surfacing and/or quick set slurry seal placed therein. This payment is an additional payment (on top of the basic payment per ton of Micro-surfacing and/or quick set slurry seal) for Micro-surfacing and/or quick set slurry seal placed in the five boroughs of New York City.

Payment for additional flaggers (if required) will be made based on the number of days (computed to the nearest quarter day) that additional flaggers are utilized as directed by the Engineer or Authorized User Representative.

Payment for optional pilot vehicles with drivers will be made based on the number of days (computed to the nearest quarter day) that optional pilot vehicles with drivers are utilized as directed by the Engineer or Authorized User Representative.

Payment for optional additional construction signs will be made based on the number of square feet (computed to the nearest tenth of a square foot) of additional construction signs that are utilized as directed by the Engineer or Authorized User Representative.

Payment for abrading the existing pavement markings, with work zone traffic control by the Authorized User (if required) will be made based on the number of linear feet at 4-inches wide of pavement markings actually abraded as directed by the Engineer or Authorized User Representative.

Payment for abrading the existing pavement markings, with work zone traffic control by the Contractor (if required), will be made based on the number of linear feet at 4-inches wide of pavement markings actually abraded as directed by the Engineer or Authorized User Representative. No separate payment will be made for work zone traffic control when this item is used.

Payment for milling recesses to receive pavement markings, with work zone traffic control by the Authorized User (if required), will be made based on the number of linear feet milled as directed by the Engineer or Authorized User Representative.

Payment for milling recesses to receive pavement markings, with work zone traffic control by the Contractor (if required), will be made based on the number of linear feet milled as directed by the Engineer or Authorized User Representative. No separate payment will be made for work zone traffic control when this item is used.

Payment for longitudinal joint repair will be made based on the actual number of tons of Micro-surfacing placed for longitudinal joint repair. This payment is an additional payment on top of the basic payment for Micro-surfacing used for longitudinal joint repair.

### 5.6 Pre-Micro-surfacing and/or Quick Set Slurry Seal Meeting

The Contractor shall schedule a pre-Micro-surfacing and/or quick set slurry seal meeting with the affected Resident Engineer or Authorized User Representative after acceptance of the Contractor's quotation and at least one week prior to the start of the Micro-surfacing and/or quick set slurry seal. Project level supervisors for both the Authorized User and the Contractor should be present at this meeting. At this meeting, the Contractor shall present their proposed Micro-surfacing and/or quick set slurry seal schedule (including design curing time), procedure, and Traffic Control Plan (if applicable) to the Authorized User for approval along with a copy of their letter of approval for their proposed Micro-surfacing and/or quick set slurry seal equipment. Prior to the start of Micro-surfacing and/or quick set slurry seal, the Contractor shall coordinate the details of the Micro-surfacing and/or quick set slurry seal with the Resident Engineer or Authorized User Representative.

### 5.7 Supervision

The Authorized User shall provide supervision for the Micro-surfacing and/or quick set slurry seal. The Resident Engineer or Authorized User Representative shall designate a Micro-surfacing and/or quick set slurry seal supervisor, and that person shall be in charge of and responsible for the operation. The following portions of Section 105 – CONTROL OF WORK of the Standard Specifications shall apply to these projects: 105-01 ENGINEER'S AUTHORITY, 105-05 VENDOR RESPONSIBILITY, 105-06 COOPERATION WITH UTILITIES AND OTHER CONTRACTORS.

### 5.8 Work Hours

Work will not be permitted on Sundays and Holidays unless ordered by the Authorized User. If the Contractor desires to work overtime on other days, dispensation from the NYS Labor Department must be obtained using Department of Labor Form PW-30.

LOT 5: MICRO-SURFACING AND/OR QUICK SET SLURRY SEAL (Cont'd)

**5.9 Construction Details**

The construction details shall comply with the requirements specified in the enclosed Attachment 11 - *Detailed Specifications – Liquid Bituminous Materials*. The Contractor shall inform the Micro-surfacing and/or quick set slurry seal Supervisor of significant deviations from the specifications.

**5.10 Restoration of Disturbed Areas**

During the course of the work, the Contractor shall take reasonable care not to disturb areas outside the existing pavement. Any areas disturbed by the Contractor shall be returned to their original condition at no expense to the owner. Any and all debris generated as part of the work shall be removed by the Contractor upon completion of the project.

**5.11 Damaged or Deficient Areas**

Prior to acceptance and payment for the Micro-surfacing and/or quick set slurry seal by the Authorized User, any mixture that ravel, delaminates, streaks because of oversize stone, fails to properly cure, or is in anyway defective shall be redone to the satisfaction of the Resident Engineer or Authorized User Representative at the Contractor's expense. After acceptance, the terms and conditions of the section of this Invitation for Bids entitled BONDING REQUIREMENTS, Section A, Item 1, Maintenance Material Bond shall control when the Contractor shall repair all defective Micro-surfacing. Bonding requirements pertain only to Micro-surfacing projects and not to quick set slurry seal projects.

**5.12 Optional Work Zone Traffic Control**

The Contractor shall submit per ton prices for work zone traffic control for the various options and quantity ranges as prescribed by this specification. When requesting price quotations from the Contractors, the Authorized User may at their option, include work zone traffic control by the Contractor for the specific project anticipated.

If optional work zone traffic control is included in the quick quoting process, the Contractor shall be responsible for Work Zone Traffic Control. Traffic shall be controlled in accordance with the Manual of Uniform Traffic Control Devices (MUTCD) and Sections 619-1 through 619-3 of the Standard Specifications including modifications to the Standard Specifications. The Contractor shall submit a Work Zone Traffic Control Plan for approval to the Resident Engineer at the Pre-Micro-surfacing Meeting. For two-way roadways, NYSDOT 619 Standard Sheets 619-307, 619-308, 619-309, 619-312 and 619-314 may be used as a basis for development of a Work Zone Traffic Control Plan. For one-way roadways, NYSDOT 619 Standard Sheets 619-302, 619-303, and 619-313 may be used as a basis for development of a Work Zone Traffic Control Plan. For one-way Freeways or Expressways, NYSDOT 619 Standard Sheets 619-301, 619-302, 619-304, and 619-305 may be used as a basis for development of a Work Zone Traffic Control Plan. A link to NYSDOT 619 Standard Sheets can be found on Attachment 14 – *NYSDOT Work Zone Traffic Control* included within this Invitation for Bids.

All necessary flaggers for work zone traffic control shall be provided by the Contractor. For two-way roadways, a minimum of three flaggers shall be provided while the Micro-surfacing and/or quick set slurry seal operation is underway. One shall be stationed at each end of the operation, and one shall be stationed with the Micro-surfacing and/or quick set slurry seal machine. For one-way roadways, a minimum of two flaggers shall be provided while the Micro-surfacing and/or quick set slurry seal operation is underway. One shall be stationed at the beginning of the operation, and one shall be stationed with the Micro-surfacing and/or quick set slurry seal machine. The Contractor shall station flaggers such that communication is maintained between the flaggers. Hand signals, radios, pilot vehicles, or some other means of communication may be used subject to the approval of the Resident Engineer or Authorized User Representative.

The Contractor shall provide construction signs as specified in Section 619-1 through 619-3 of the Standard Specifications and in the MUTCD.

**LOT 5: MICRO-SURFACING AND/OR QUICK SET SLURRY SEAL (Cont'd)**

At a minimum, the Contractor shall install the following permanent construction signs supplemented by temporary signs as needed:

Sign	Minimum Size	Location
ROAD WORK NEXT _____ MILES	<u>G20-1</u> Conventional 36" x 18" Freeways 48" x 24"	On main line upstream of project in each direction.
END ROAD WORK	<u>G20-2</u> Conventional 36" x 18" Freeways 48" x 24"	On main line after end of project in each direction.
ROAD WORK AHEAD	<u>W20-1</u> Conventional 36" x 36" Freeways 48" x 48"	On main line in advance of the affected highway segment in each direction and on major intersecting roads 300-500 feet in advance of main line. Sign should be covered if it conflicts with temporary signing in the vicinity. (Place between the G20-1 and the first warning sign that states condition - i.e. W8-12, W8-9 or W8-15).
DO NOT PASS	<u>R4-1</u> Conventional 24" x 30"	If 2' x 4" temporary yellow markings are used instead of full barrier centerline pavement markings, place the first sign at or within 100-feet of the beginning of the unmarked area, second within 1,000-feet and subsequent signs, spaced every ½ mile along project in each direction.
NO CENTER LINE	<u>W8-12</u> Conventional 36" x 36"	If 2' x 4" temporary yellow markings are used instead of full barrier centerline pavement markings, place the first sign in advance of the condition and the first "DO NOT PASS" sign: 300' urban is preferred (100' minimum), 500' rural is preferred (200' minimum). Place additional signs spaced every 2 miles on mainline in each direction and after every major intersecting road.

\*\*All signs should maintain an absolute minimum spacing of 200' rural or 100' urban. 500' is preferred on rural and 300' is preferred on urban. Double stacking of any of the above signs, or combination thereof, will NOT be permitted.

Major intersecting roads are defined as State, County, Town, Village, or City roads. The Contractor may provide portable signs as shown in Figure 6F-2 of the MUTCD and meeting the requirements of Section 619 of the Standard Specifications for lane closures during work hours.

With prior permission of the State's Resident Engineer or Authorized User Representative, the Contractor may provide portable signs as shown in Figure 6F-2 of the MUTCD for the above referenced DO NOT PASS and NO CENTER LINE signs. Signs left active at night shall be rigid and reflectorized in accordance with the Standard Specifications. The Contractor shall be responsible for assuring that all signs will be in their upright, visible positions twenty-four hours a day, seven days a week while 2' x 4" temporary yellow markings are used instead of full barrier pavement markings.

**LOT 5: MICRO-SURFACING AND/OR QUICK SET SLURRY SEAL (Cont'd)**

**5.12.1 Special Note: Temporary Pavement Markings**

The Contractor shall install and maintain temporary pavement markings on any paved surface without permanent pavement markings before opening it to traffic, before nightfall or before the end of the workday, whichever comes soonest except for areas that are open during the work shift with channelizing devices or flaggers. Temporary pavement markings shall meet the requirements of Section 619 of the Standard Specifications except that two-lane, two-way highways may be left without full barrier centerlines in no passing zones for a maximum of 7 calendar days provided that NO CENTER LINE (W8-12, black on orange), NO PASSING ZONE (W14-3, black on orange pennant shaped sign), and DO NOT PASS (R4-1) signs are used consistent with the MUTCD and in conjunction with yellow 2-foot by 4-inch temporary markings consisting of retro-reflective removable pavement marking tape, paint or yellow temporary overlay markers installed on a 40-foot cycle to delineate the centerline location.

The Authorized User is responsible for the final pavement markings unless otherwise indicated in the contract. If the Contractor chooses to install NO CENTER LINE and DO NOT PASS signs and temporary yellow 2-foot by 4-inch pavement markings in lieu of full barrier centerline markings, the signs shall be left in place until the Authorized User has completed installing the final pavement markings. The Authorized User will normally complete final pavement markings within 7 days of the project completion. However, if unavoidable situations delay the pavement marking installation the signs shall remain in place for 14 calendar days after the project has been completed or until the Authorized User has completed installing the final pavement markings, whichever comes first. If permanent pavement marking cannot be installed within 14 days of the project completion, Authorized User must install interim pavement marking including center lines, edge lines, stop bars, and simple crosswalks with no hatching before the end of 14 days after project completion.

All costs for Work Zone Traffic Control including flagging, temporary pavement markings, delineation, and construction signs are to be included in the prices bid per ton for optional work zone traffic control. No separate payment shall be made.

**5.12.2 Additional Flaggers for Work Zone Traffic Control**

If the Engineer or Authorized User Representative determines that more than 3 flaggers are necessary to properly control traffic on two-way roadways or more than 2 flaggers are necessary to properly control traffic on one-way roadways and the Contractor is responsible for work zone traffic control under this Invitation for Bids, the Contractor shall provide additional flaggers under the Additional Flaggers item. The price bid per flagger per day shall include all costs of providing a flagger where directed by the Engineer or Authorized User Representative with all the necessary safety equipment, i.e. stop/slow paddle, flag, vest, hardhat, etc. Payment shall be by the day for each flagger provided. A day shall be determined as including the time period between the commencement and completion of work on any calendar day. No extra payment shall be provided if the Contractor elects to work a longer day than the standard eight-hour workday. Payment shall be made to the nearest quarter day as determined by the Engineer or Authorized User Representative.

**5.12.3 Optional Pilot Vehicles with Drivers**

If required by the Engineer or Authorized User Representative, the Contractor shall provide sufficient two-way radio equipped pilot vehicles with drivers to guide traffic around the Micro-surfacing and/or quick set slurry seal work zone at a maximum of 20 miles per hour. Payment shall be by the day for each pilot vehicle with driver provided. A day shall be determined as including the time period between the commencement and completion of work on any calendar day. No extra payment shall be provided if the Contractor elects to work a longer day than the standard eight-hour workday. Payment shall be made to the nearest quarter day as determined by the Engineer or Authorized User Representative.

The pilot vehicle(s) shall be equipped with construction signs meeting the requirements of Section 6F.58 of the MUTCD and a rotating amber beacon:

Sign	Minimum Size	Location
PILOT CAR FOLLOW ME	G20-4 Conventional 36" x 18"	On the back of the pilot vehicle.

The pilot vehicle shall have the name of the Contractor prominently displayed.

**LOT 5: MICRO-SURFACING AND/OR QUICK SET SLURRY SEAL (Cont'd)**

**5.12.4 Optional Additional Construction Signs**

If the Engineer or Authorized User Representative determines that more permanent construction signs are necessary than those called out under the Optional Work Zone Traffic Control section and the Contractor is responsible for work zone traffic control under this Invitation for Bids, the Contractor shall provide additional construction signs under the Optional Additional Construction Signs item. Optional Additional Construction Signs shall be as specified in Sections 619-1 through 619-3 of the Standard Specifications and/or in the MUTCD, or as specified by the Engineer or Authorized User Representative. The price bid per square foot shall include all costs of providing the signs as indicated by the Engineer or Authorized User Representative, the sign supports, installation and removal at locations ordered by the Engineer or Authorized User Representative. Payment shall be made by the square foot of construction sign face, computed to the nearest tenth of a square foot.

**5.12.5 Abrading of Existing Pavement Markings with Work Zone Traffic Control by the Authorized User**

If the Contractor, with the concurrence of the Resident Engineer or Authorized User Representative, determines that it is necessary for the performance of the Micro-surfacing and/or quick set slurry seal, the Contractor shall abrade the existing pavement markings so that at least 75% of the glass beads in the existing pavement markings are removed. The method of abrading may include sand blasting, water blasting, grinding, or other method approved by the Engineer or Authorized User Representative. Care shall be taken to avoid damage to passing traffic. All damage to passing traffic caused by the Contractor's operations shall be the Contractor's responsibility. Traffic will be controlled by the Authorized User.

Payment will be made by the linear foot of pavement marking 4-inches wide. Payment for pavement markings wider than 4-inches or for pavement marking symbols will be made by the following method:

$$\frac{\text{Width of marking (inches)} \times \text{linear feet}}{4\text{-inches}}$$

The price bid for pavement marking abrading shall include all labor, materials, and equipment required to abrade the existing pavement markings to the satisfaction of the Engineer or Authorized User Representative.

**5.12.6 Abrading Existing Pavement Markings with Work Zone Traffic Control by the Contractor**

If the Contractor, with the concurrence of the Resident Engineer or Authorized User Representative, determines that it is necessary for the performance of the Micro-surfacing and/or quick set slurry seal, the Contractor shall abrade the existing pavement markings so that at least 75% of the glass beads in the existing pavement markings are removed. The method of abrading may include sand blasting, water blasting, grinding, or other methods approved by the Engineer or Authorized User Representative. Care shall be taken to avoid damage to passing traffic. All damage to passing traffic caused by the Contractor's operations shall be the Contractor's responsibility. Traffic will be controlled by the Contractor.

The Contractor shall place temporary pavement markings as specified elsewhere in this Invitation for Bids under optional work zone traffic control, unless the Micro-surfacing and/or quick set slurry seal will be placed the same day as pavement markings are abraded. During the pavement markings abrading operation, traffic will be controlled by the Contractor in accordance with the MUTCD. The Contractor shall submit a proposed Work Zone Traffic Control Plan to the Engineer or Authorized User Representative for approval. The plan may be based on the Work Zone Traffic Control included in this Invitation for Bids see Attachment 14 – *NYS DOT Work Zone Traffic Control*.

Payment will be made by the linear foot of pavement marking 4-inches wide. Payment for pavement markings wider than 4-inches or for pavement marking symbols will be made by the following method:

$$\frac{\text{Width of marking (inches)} \times \text{Linear Feet}}{4\text{-inches}}$$

The price bid for pavement marking abrading shall include all labor, materials, and equipment required to abrade the existing pavement markings and to properly control traffic to the satisfaction of the Engineer or Authorized User Representative.

LOT 5: MICRO-SURFACING AND/OR QUICK SET SLURRY SEAL (Cont'd)

**5.12.7 Special Note: Work Zone Intrusion Initiative**

As part of the NYS Department of Transportation's Work Zone Intrusion Initiative, the following countermeasures shall apply to this Invitation for Bids:

**Channelizing Device Spacing Reduction**

A maximum channelizing device spacing of 40-feet shall be provided at stationary work sites where workers are exposed to traffic. This spacing shall be maintained a reasonable distance upstream of workers and shall be used throughout the work zone.

Where tapers are located less than 500-feet from the work site, the 40-foot spacing shall be used in the taper as well.

Drums or vertical panels are preferred for long-term stationary and intermediate-term stationary work zones, and at any locations where the risk of intrusion is high. Traffic cones are normally adequate for work zones set up and removed on a daily basis.

In long lane or shoulder closures, at least two channelizing devices shall be placed transversely at maximum 800-foot intervals to discourage traffic from driving through the closed lane. **Transversely placed devices are not required where pilot cars are in use.**

Frequent checks shall be made to reset channelizing devices dislodged by traffic.

**Flagger Station Enhanced Setups**

Additional cones and a flag tree meeting Section 6F.62 of the MUTCD shall be used upstream of flagger stations to provide added warning to drivers. These devices shall be used for flagger stations except those that are constantly moving or are in use at one location for no more than a few minutes. If the W20-7a Flagger sign is required, the additional cones and flag tree shall also be used.

For additional details on Flagger Enhanced Setups, see Attachment 14 – *NYS DOT Work Zone Traffic Control* included in this Invitation for Bids.

**5.13 Detailed Specifications – Micro-surfacing and/or Quick Set Slurry Seal**

Please, see Attachment 11 - *Detailed Specifications – Liquid Bituminous Materials*.

**LOT 6: PAVER PLACED SURFACE TREATMENT – CONVENTIONAL & MODIFIED**

**6.1 Introduction**

Conventional and Modified Paver Placed Surface Treatment is a preventive maintenance treatment used to preserve highway pavements. The treatment is a surface paving system, placed by a self-priming paver, where a modified emulsion tack coat is placed directly before the application of a conventional or modified asphalt wearing course.

**6.2 Pricing Information**

**6.2.1 General**

Price quoted shall be to three (3) decimal places. Price quoted shall be F.O.B. the Contractor's location per ton based on average daily production for the conventional and modified paver placed surface treatment.

The Contractor is to furnish all necessary labor and equipment to complete the conventional or modified paver placed surface treatment work under this contract. Cleaning the existing pavement shall be the responsibility of the Authorized User. Permanent pavement striping will be the responsibility of the Authorized User upon completion of the conventional or modified paver placed surface treatment after the Contractor has vacated the project site.

The price bid for optional work zone traffic control shall be per ton of conventional or modified paver placed surface treatment.

Price quoted for additional flaggers (if required) shall be net per day (to the nearest quarter day) for additional flaggers.

Price quoted for optional pilot vehicles with drivers (if required) shall be net per day (to the nearest quarter day) for each pilot vehicle with driver.

Price quoted for optional additional construction signs shall be net per square foot (including signs, sign supports, installation, and removal) of additional construction signs.

Price quoted for additional cost per day for Saturday and Sunday work, when directed by the Resident Engineer or Authorized User Representative, shall be net per day for Saturday or Sunday work.

Price quoted for abrading the existing pavement markings by the Contractor, with work zone traffic control by the Authorized User (if required) shall be net per linear foot at 4-inches wide of pavement markings actually abraded by the Contractor. This price shall include all costs for pavement marking abrading including all labor, materials, and equipment necessary to abrade the pavement markings.

Price quoted for abrading the existing pavement markings by the Contractor, with work zone traffic control by the Contractor (if required) shall be net per linear foot at 4-inches wide of pavement markings actually abraded by the Contractor. This price shall include all costs for pavement marking abrading including all labor, materials, and equipment necessary to abrade the pavement markings and all costs to properly maintain traffic.

Price quoted for overlay splices with work zone traffic control by the Authorized User (if required) shall be net per linear foot at 3-feet wide of overlay splices actually constructed by the Contractor. This price shall include all costs for conventional or modified paver placed surface treatment overlay splices including all labor, materials, and equipment necessary to construct the overlay splices.

Price quoted for splices with work zone traffic control by the Contractor (if required) shall be net per linear foot at 3-foot wide of overlay splices actually constructed by the Contractor. This price shall include all costs for conventional or modified paver placed surface treatment overlay splices including all labor, materials, and equipment necessary to contract the overlay splices and all costs to properly control traffic.

The equipment supplied to place the conventional or modified paver placed surface treatment shall meet the appropriate requirements of the New York State Department of Transportation Standard Specifications. All necessary operators shall be supplied along with the conventional or modified paver placed surface treatment spreader and the rollers. All personnel supplied for the work under this contract shall be qualified and experienced in conventional or modified paver placed surface treatment placement.

LOT 6: PAVER PLACED SURFACE TREATMENT – CONVENTIONAL & MODIFIED  
(Cont'd)

**Price Additional for Mobilization from Contractor’s Location to Project Location** - Price additional quoted for mobilization from Contractor’s location to project location shall be net per ton of accepted conventional or modified paver placed surface treatment in place performed at the locations indicated by the State’s Resident Engineer or Authorized User Representative. Conventional or modified paver placed surface treatment shall be performed in accordance with NYSDOT’s Standard Specifications and as per the attached specifications for conventional or modified paver placed surface treatment. Cleaning the existing pavement will be the responsibility of the Authorized User. Erecting warning signs and directing traffic will be the responsibility of the Authorized User or the Contractor using the optional work zone traffic control section of this Invitation for Bids at the discretion of the Authorized User.

**6.2.2 Insurance**

Please refer to Section 6.19 - Insurance of the Invitation for Bids for information about insurance.

**6.3 Asphalt Price Adjustments – Paver Placed Surface Treatment**

**6.3.1 General**

- a. Asphalt price adjustments allowed will be based on the November 1, 2025 average of the F.O.B. terminal price per ton of unmodified PG 64S-22 binder without anti-stripping agent (base average F.O.B. terminal price). The new monthly average terminal price will be determined by the New York State Department of Transportation based on prices of pre-approved primary sources of performance graded binder in accordance with the New York State Department of Transportation Standard Specification.

**The November 1, 2025 average is \$638.000**

**NOTE:** The same grade of asphalt cement used in establishing the base average F.O.B. terminal price shall be used in establishing the new average F.O.B. terminal price.

In the event that one or more of the New York State Department of Transportation pre-approved sources discontinue posting a price for asphalt cement, the base average F.O.B. terminal **price shall not be recalculated.**

- b. The new average F.O.B. terminal price will be determined based on the above F.O.B. terminal prices posted each month during the contract period. However, asphalt price adjustments, in accordance with the formula below, will be effective for deliveries made on and after the first of the month following the adjustment date.
- c. The unit prices of bituminous materials purchased from any award based on this specification will be subject to adjustment based on the following formula:

$\text{Price Adjustment (Per Ton)} = \left( \frac{\text{New Monthly Average F.O.B. Terminal Price} - \text{Base Average F.O.B. Terminal Price}}{\text{F.O.B. Terminal Price}} \right) \times \text{Total Allowable Petroleum \%}$
---

Positive Price Adjustment number shall be added to original per ton Bid Price.

Negative Price Adjustment number shall be subtracted from original per ton Bid Price.

LOT 6: PAVER PLACED SURFACE TREATMENT – CONVENTIONAL & MODIFIED  
(Cont'd)

**New Monthly Average F.O.B. Terminal Price**

The average F.O.B. terminal price for unmodified PG 64S-22 binder without anti-stripping agent is as determined by the New York State Department of Transportation per New York State Department of Transportation Standard Specification.

**Base Average F.O.B. Terminal Price**

The average F.O.B. terminal price of unmodified PG 64S-22 binder without anti-stripping agent is as determined by the New York State Department of Transportation as of November 1, 2025.

**Total Allowable Petroleum**

The percentage of total allowable petroleum for each item is as follows:

Item #	Asphalt %	Petroleum Allowance %	Total Allowable Petroleum %
415.0X0F0218	6.5	1.0	7.5
415.0X0F0218	6.5	1.0	7.5

Asphalt Price Adjustments will not be allowed for materials which do not have an asphalt cement base.

- d. Work performed after the expiration of the contract, where no extension has been granted, resultant from purchase orders placed prior to expiration of the contract will be based on the new average for the month in which the work is done applying the same base established for that contract.

Asphalt Price Adjustments for any contracts that are extended will be based on the new average for the month in which the work is done applying the same base established for that contract.

- e. Asphalt Price Adjustments allowed by this contract shall be calculated and applied to the original prices. There will not be Asphalt Price Adjustments unless the change amounts to more than \$0.10 per ton from the original price. In these instances, prices will revert back to the original prices.
- f. All Asphalt Price Adjustments will be computed to three decimal places.
- g. Should these provisions result in a price structure which becomes unworkable, detrimental or injurious to the State or in prices which are not truly reflective of market conditions or which are deemed by the Commissioner to be unreasonable or excessive, and no adjustment in price is mutually agreeable, the Commissioner reserves the sole right upon ten days written notice mailed to the Contractor to terminate any contract resulting from this bid opening.
- h. All Asphalt Price Adjustments shall be published by the State and issued to all contract holders whose responsibility will be to attach the appropriate State notification (based on when the work was performed) to the payment invoice submitted to the Authorized User.

LOT 6: PAVER PLACED SURFACE TREATMENT – CONVENTIONAL & MODIFIED  
(Cont'd)

**6.3.2 Asphalt Price Adjustment – Paver Placed Surface Treatment: Example**

This example is for illustration purposes only. Actual Base Average Price, etc., may vary.

Item 415.01010218

Base Average Price = \$638.000

New Average Price = \$648.000

% Total Allowable Petroleum = 7.5%

$$\begin{array}{l}
 \boxed{\begin{array}{c} \text{Price} \\ \text{Adjustment} \\ \text{(per ton)} \end{array}} = \boxed{(648.000 - 638.000)} \times \boxed{0.075} \\
 \\
 \boxed{\begin{array}{c} \text{Price} \\ \text{Adjustment} \\ \text{(per ton)} \end{array}} = \boxed{+\$0.750 \text{ per ton}}
 \end{array}$$

Positive Price Adjustment number shall be added to original per ton Bid Price.

Negative Price Adjustment number shall be subtracted from original per ton Bid Price.

**6.4 Minimum Quantities**

The minimum project size for conventional and modified paver placed surface treatment under this contract shall be **50 tons**. This is approximately 0.12 miles of two-lane highway at 20-feet wide. A quantity/price change per day occurs at **150 tons**, which is approximately 0.35 miles of a two-lane highway at 20-feet wide. A second quantity/price change per day occurs at **500 tons**, which is approximately 1.2 miles of a two-lane highway at 20-feet wide. A third quantity/price change per day occurs at **1000 tons**, which is approximately 2.4 miles of a two-lane highway at 20-feet wide.

**6.5 Delivery Ticket**

A delivery ticket shall be provided with each load of bituminous asphalt emulsions stating the following:

1. Storage facility identification
2. Ticket Number
3. Date/time
4. Item Number and Type
5. Quantity ticket printed by machine
6. Quantity in 60°F gallons for emulsions

**6.6 Payment**

Payment for conventional and modified paver placed surface treatment in place shall be made at the contract price per unit bid for the actual number of tons of conventional or modified paver placed surface treatment in place verified by the Authorized User and used in the accepted portion of the work. The determination as to quantities involved in this contract shall be accepted as final and binding upon the Contractor.

A delivery slip stating quantities of asphalt concrete for conventional or modified paver placed surface treatment shall accompany each shipment. An invoice listing the quantities of conventional or modified paver placed surface treatment in place shall be sent promptly by the Contractor to the State's Resident Engineer or to the Authorized User Representative placing the order. Payment for optional work zone traffic control (if required) will be made based on the average daily production in tons per day of completed conventional or modified paver placed surface treatment.

Payment for additional flaggers (if required) will be made based on the number of days (computed to the nearest quarter day) that additional flaggers are utilized as directed by the Engineer or Authorized User Representative.

Payment for optional pilot vehicles with drivers will be made based on the number of days (computed to the nearest quarter day) that optional pilot vehicles with drivers are utilized as directed by the Engineer or Authorized User Representative.

## LOT 6: PAVER PLACED SURFACE TREATMENT – CONVENTIONAL & MODIFIED (Cont'd)

Payment for optional additional construction signs will be made on the number of square feet (computed to the nearest tenth of a square foot) of additional construction signs that are utilized as directed by the Engineer or Authorized User Representative.

Payment for work on Saturday and/or Sunday will be based on the actual number of days worked at the direction of the Resident Engineer or Authorized User Representative.

Payment for abrading the existing pavement markings by the Contractor, with work zone traffic control by the Authorized User (if required) will be made based on the number of linear feet at 4-inches wide of pavement markings actually abraded as directed by the Engineer or Authorized User Representative.

Payment for abrading the existing pavement markings by the Contractor, with work zone traffic control by the Contractor (if required), will be made based on the number of linear feet at 4-inches wide of pavement markings actually abraded as directed by the Engineer or Authorized User Representative. No separate payment will be made for work zone traffic control when this item is used.

Payment for overlay splices with work zone traffic control by the Authorized User (if required) will be made based on the number of linear feet of overlay splices at 3-feet wide actually constructed by the Contractor as directed by the Engineer or Authorized User Representative.

Payment for overlay splices with work zone traffic control by the Contractor (if required) will be made based on the number of linear feet of overlay splices at 3-feet wide actually constructed by the Contractor as directed by the Engineer or Authorized User Representative. No separate payment will be made for maintenance and protection of traffic when this item is used.

The price per unit arrived at (mutually estimated) by the Contractor and the Authorized User on the Price Calculation Worksheet or the price per unit resultant from the average daily production, whichever is less, shall be the price per unit paid to the Contractor. No additional payment shall be due to the Contractor for production rates that are not equal to the rate upon which the calculation work sheet price was based.

### **6.7 Pre-Conventional or Modified Paver Placed Surface Treatment Meeting**

The Contractor shall schedule a pre-conventional or modified paver placed surface treatment meeting with the Authorized User at least two weeks prior to the start of work under this contract. Project level supervisors for both the Authorized User and the Contractor will be present at this meeting. At this meeting the Contractor shall present Certificates of Insurance evidencing compliance with the additional insurance requirements, their proposed schedule, mix design, numbers and type of equipment, and Work Zone Traffic Control (if applicable) to the Authorized User for approval. The mix design must clearly show all the target gradations and asphalt content used in the mix design and shall be representative of the materials proposed by the Contractor to be used on the project. Adjustments may be required during construction based on field conditions and with the approval of the Authorized User. The Contractor shall also furnish the Authorized User copies of the self-priming paver approval at this time. The Contractor shall indicate the aggregate source and the asphalt concrete source, at this meeting. At least one week prior to the start of work under this contract, the Contractor shall coordinate the details of the conventional or modified paver placed surface treatment with the Authorized User Representative.

### **6.8 Supervision**

The Authorized User shall provide supervision for the paver placed surface treatment operation. The Resident Engineer or Authorized User Representative shall designate a paver placed surface treatment supervisor and that person shall be in charge of and responsible for the operation. The following portions of Section 105 - CONTROL OF WORK of the Standard Specifications shall apply to these projects: 105-01 ENGINEER'S AUTHORITY, 105-05 VENDOR RESPONSIBILITY, 105-06 COOPERATION WITH UTILITIES AND OTHER CONTRACTORS.

### **6.9 Work Hours**

Work will not be permitted on Sundays and Holidays unless requested by the Authorized User. If the Contractor desires to work overtime on other days, dispensation from the NYS Labor Department must be obtained using Department of Labor Form PW-30.

LOT 6: PAVER PLACED SURFACE TREATMENT – CONVENTIONAL & MODIFIED  
(Cont'd)

**6.10 Construction Details**

The construction details shall comply with the requirements specified in the enclosed Attachment 11 – Detailed Specifications – Liquid Bituminous Materials.

**6.11 Saturday and Sunday Work**

When requested to work on Saturday and/or Sunday by the Resident Engineer or Authorized User Representative, the Contractor shall be paid the price bid for Saturday and/or Sunday work, as appropriate. The price bid per day shall include the cost of all premium labor charges. The Contractor shall only be due the extra payment when work on Saturday and/or Sunday is in the best interest of the Authorized User. Work done by the Contractor on Saturday and/or Sunday for their own convenience or to make up for rainouts shall not be due the extra payment for Saturday and/or Sunday work.

**6.12 Damaged or Deficient Areas**

Prior to acceptance and payment for work under this contract by the Authorized User, any conventional or modified paver placed surface treatment that ravels, delaminates, fails to properly cure, or is in any way defective shall be redone to the satisfaction of the Authorized User Representative at the Contractor's expense.

**6.13 Optional Overlay Splices with Work Zone Traffic Control by the Authorized User**

If required by the Engineer or Authorized User Representative, the Contractor shall construct overlay splices (commonly known as rebates) as per the detail Overlay Splices (see next page). The price bid shall include all costs to properly construct the overlay splice including the costs for cutting the existing pavement, milling overlay splices, and cleaning the pavement in the splice area. Payment shall be by the linear foot of overlay splice at 3-feet wide. Work zone traffic control shall be the responsibility of the Authorized User.

**6.14 Optional Overlay Splices with Work Zone Traffic Control by the Contractor**

If required by the Engineer or Authorized User Representative, the Contractor shall construct overlay splices (commonly known as rebates) as per the detail Overlay Splices (see next page). The price bid shall include all costs to properly construct the overlay splice including the costs for cutting the existing pavement, milling overlay splices, cleaning the pavement in the splice area, and maintaining and protecting traffic. Payment shall be by the linear foot of overlay splice at 3-feet wide. Work zone traffic control shall be the responsibility of the Contractor.

**6.15 Optional Work Zone Traffic Control**

The Contractor shall submit a per square yard price for work zone traffic control as prescribed by this specification. When requesting price quotes from the Contractors, the Authorized User may, at their option, include work zone traffic control by the Contractor for the specific project anticipated.

If optional work zone traffic control is included in the quick quoting process, the Contractor shall be responsible for Work Zone Traffic Control. Traffic shall be controlled in accordance with the Manual of Uniform Traffic Control Devices (MUTCD) and Sections 619-1 through 619-3 of the Standard Specifications including modifications to the Standard Specifications. The Contractor shall submit a Work Zone Traffic Control Plan for approval to the Resident Engineer at the Pre-Paver Placed Surface Treatment Meeting. For two-way roadways, NYSDOT 619 Standard Sheets 619-307, 619-308, 619-309, 619-312 and 619-314 may be used as a basis for development of a Work Zone Traffic Control Plan. For one-way roadways, NYSDOT 619 Standard Sheets 619-302, 619-303, and 619-313 may be used as a basis for development of a Work Zone Traffic Control Plan. For one-way Freeways or Expressways, NYSDOT 619 Standard Sheets 619-301, 619-302, 619-304, and 619-305 may be used as a basis for development of a Work Zone Traffic Control Plan. A link to NYSDOT 619 Standard Sheets can be found on Attachment 14 – *NYSDOT Work Zone Traffic Control* included within this Invitation for Bids.

LOT 6: PAVER PLACED SURFACE TREATMENT – CONVENTIONAL & MODIFIED  
(Cont'd)

OPTIONAL OVERLAY SPLICE:

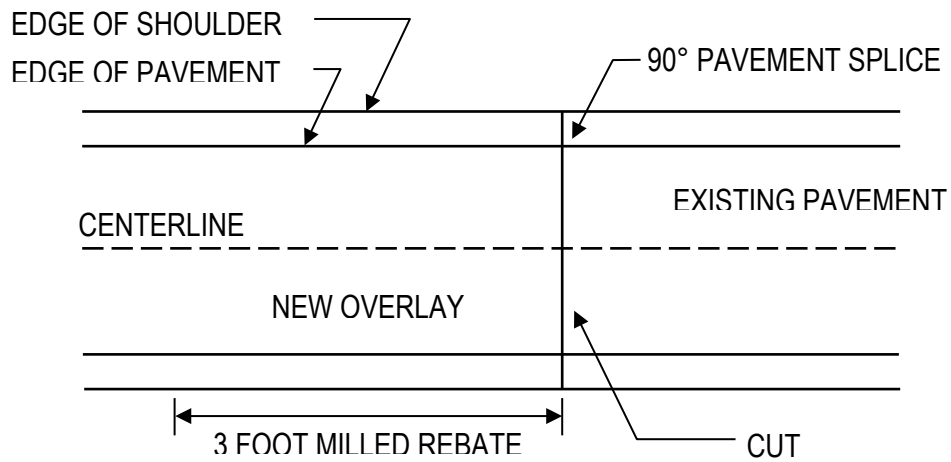

PLAN

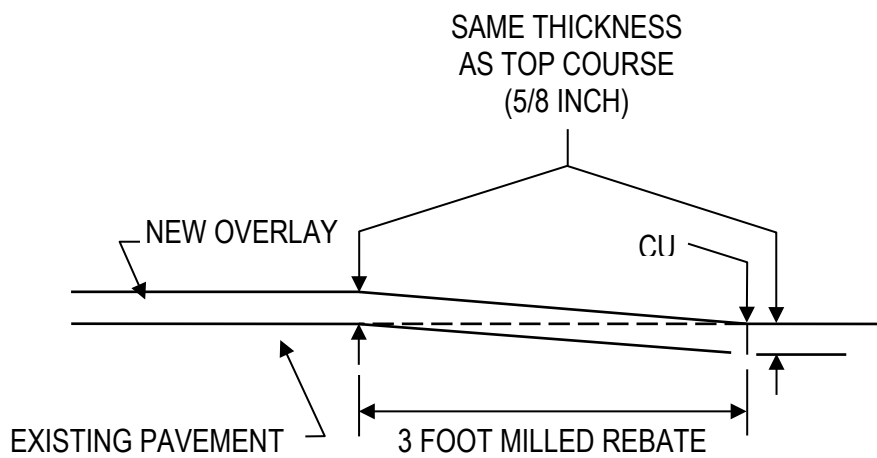

SECTION

**LOT 6: PAVER PLACED SURFACE TREATMENT – CONVENTIONAL & MODIFIED  
(Cont'd)**

Unless otherwise specified, the highway shall be kept open to traffic at all times. Traffic shall be discontinued on the lane where the conventional or modified paver placed surface treatment is being placed; and as soon as the newly paved surface has been rolled, traffic may be permitted thereon. The Contractor shall provide construction signs as specified in Section 619-1 through 619-3 of the Standard Specifications and in the MUTCD. At a minimum the Contractor shall install the following permanent construction signs:

Sign	Minimum Size	Location
ROAD WORK NEXT _____ MILES	<u>G20-1</u> Conventional 36" x 18"  Freeways 48" x 24"	On main line upstream of project in each direction.
END ROAD WORK	<u>G20-2</u> Conventional 36" x 18"  Freeways 48" x 24"	On main line after end of project in each direction.
ROAD WORK AHEAD	<u>W20-1</u> Conventional 36" x 36"  Freeways 48" x 48"	On main line in advance of the affected highway segment in each direction and on major intersecting roads 300-500 feet in advance of main line. Sign should be covered if it conflicts with temporary signing in the vicinity. (Place between the G20-1 and the first warning sign that states condition- i.e. W8-12, W8-9 or W8-15).
DO NOT PASS	<u>R4-1</u> Conventional 24" x 30"	If 2' x 4" temporary yellow markings are used instead of full barrier centerline pavement markings, place the first sign at or within 100-feet of the beginning of the unmarked area, second within 1,000-feet and subsequent signs, spaced every ½ mile along project in each direction.
NO CENTER LINE	<u>W8-12</u> Conventional 36" x 36"	If 2' x 4" temporary yellow markings are used instead of full barrier centerline pavement markings, place the first sign in advance of the condition and the first "DO NOT PASS" sign: 300' urban is preferred (100' minimum), 500' rural is preferred (200' minimum). Place additional signs spaced every 2 miles on mainline in each direction and after every major intersecting road.
LOW SHOULDER	<u>W8-9</u> Conventional 36" x 36"  Freeways 48" x 48"	Place on mainline spaced every 2 miles along project in each direction and after every major intersecting road until shoulder back-up is installed (if conditions warrant use, place between the W8-12 and R4-1, maintaining a minimum of 200' between signs for rural roads and 100' on urban. The W8-12 can be moved upstream to accommodate the required spacing.)
GROOVED PAVEMENT	<u>W8-15</u> Conventional 36" x 36"  Freeways 48" x 48"	On any roadway 500-feet in advance of rebates milled under this contract but not paved. Remove or cover after paving rebate.

\*\*All signs should maintain an absolute minimum spacing of 200' rural or 100' urban. 500' is preferred on rural and 300' is preferred on urban. Double stacking of any of the above signs, or combination thereof, will NOT be permitted.

## LOT 6: PAVER PLACED SURFACE TREATMENT – CONVENTIONAL & MODIFIED (Cont'd)

Major intersecting roads are defined as State, County, Town, Village, or City roads. The Contractor may provide portable signs as shown in Figure 6F-2 of the MUTCD and meeting the requirements of the Standard Specifications for lane closures during work hours.

With prior permission of the State's Resident Engineer or Authorized User Representative, the Contractor may provide portable signs as shown in Figure 6F-2 for the above referenced DO NOT PASS and NO CENTER LINE signs. Signs left active at night shall be rigid and reflectorized in accordance with the Standard Specifications. The Contractor shall be responsible for assuring that all signs will be in their upright, visible positions twenty-four hours a day, seven days a week while 2' x 4" temporary yellow markings are used instead of full barrier pavement markings.

### 6.15.1 Special Note: Temporary Pavement Markings

The Contractor shall install and maintain temporary pavement markings on any paved surface without permanent pavement markings before opening it to traffic, before nightfall or before the end of the workday, whichever comes soonest except for areas that are open during the work shift with channelizing devices or flaggers. Temporary pavement markings shall meet the requirements of Section 619 of the Standard Specifications except that two-lane, two-way highways may be left without full barrier centerlines in no passing zones for a maximum of 7 calendar days provided that NO CENTER LINE (W8-12, black on orange), NO PASSING ZONE (W14-3, black on orange pennant shaped sign), and DO NOT PASS (R4-1) signs are used consistent with the MUTCD and in conjunction with yellow 2-foot by 4-inch temporary markings consisting of retro-reflective removable pavement marking tape, paint or yellow temporary overlay markers installed on a 40 foot cycle to delineate the centerline location.

The Authorized User is responsible for the final pavement markings unless otherwise indicated in the contract. If the Contractor chooses to install NO CENTER LINE and DO NOT PASS signs and temporary yellow 2-foot by 4-inch pavement markings in lieu of full barrier centerline markings, the signs shall be left in place until the Authorized User has completed installing the final pavement markings. The Authorized User will normally complete final pavement markings within 7 days of the project completion. However, if unavoidable situations delay the pavement marking installation the signs shall remain in place for 14 calendar days after the project has been completed or until the Authorized User has completed installing the final pavement markings, whichever comes first. If permanent pavement marking cannot be installed within 14 days of the project completion, Authorized User must install interim pavement marking including center lines, edge lines, stop bars, and simple crosswalks with no hatching before the end of 14 days after project completion.

All costs for Work Zone Traffic Control including flagging, temporary pavement markings, delineation, and construction signs are to be included in the prices bid per ton for optional work zone traffic control. No separate payment shall be made.

### 6.15.2 Additional Flaggers for Work Zone Traffic Control

If the Engineer or Authorized User Representative determines that more than 3 flaggers are necessary to properly control traffic on two-way roadways or more than two flaggers are necessary to properly control traffic on one-way roadways and the Contractor is responsible for work zone traffic control under this Invitation for Bids, the Contractor shall provide additional flaggers under the Additional Flaggers item. The price bid per flagger per day shall include all costs of providing a flagger where directed by the Engineer or Authorized User Representative with all the necessary safety equipment, i.e. stop/slow paddle, flag, vest, hardhat, etc. Payment shall be by the day for each flagger provided. A day shall be determined as including the time period between the commencement and completion of work on any calendar day. No extra payment shall be provided if the Contractor elects to work a longer day than the standard eight-hour workday. Payment shall be made to the nearest quarter day as determined by the Engineer or Authorized User Representative.

**LOT 6: PAVER PLACED SURFACE TREATMENT – CONVENTIONAL & MODIFIED  
(Cont'd)**

**6.15.3 Optional Pilot Vehicle with Drivers**

The Contractor shall provide sufficient two-way radio equipped pilot vehicles with drivers to guide traffic around the paver placed surface treatment work zone at a maximum of 20 miles per hour. Payment shall be by the day for each pilot vehicle with driver provided. A day shall be determined as including the time period between the commencement and completion of work on any calendar day. No extra payment shall be provided if the Contractor elects to work a longer day than the standard eight-hour workday. Payment shall be made to the nearest quarter day as determined by the Engineer or Authorized User Representative. The pilot vehicle(s) shall be equipped with construction signs meeting the requirements of Section 6F.58 of the MUTCD and a rotating amber beacon:

Sign	Minimum Size	Location
PILOT CAR FOLLOW ME	<u>G20-4</u> 36" X 18"	ON BACK OF PILOT VEHICLES.

The pilot vehicle shall have the name of the Contractor prominently displayed.

**6.15.4 Optional Additional Construction Signs**

If the Engineer or Authorized User Representative determines that more permanent construction signs are necessary than those called out under the Optional Work Zone Traffic Control section and the Contractor is responsible for work zone traffic control under this Invitation for Bids, the Contractor shall provide additional construction signs under the Optional Additional Construction Signs item. Optional Additional Construction Signs shall be as specified in Sections 619-1 through 619-3 of the Standard Specifications and/or in the MUTCD, or as specified by the Engineer or Authorized User Representative. The price bid per square foot shall include all costs of providing the signs as indicated by the Engineer or Authorized User Representative, the sign supports, installation and removal at locations ordered by the Engineer or Authorized User Representative. Payment shall be made by the square foot of construction sign face, computed to the nearest tenth of a square foot.

**6.15.5 Abrading Existing Pavement Markings with Work Zone Traffic Control by the Authorized User**

If the Contractor, with the concurrence of the Resident Engineer or Authorized User Representative, determines that it is necessary for the performance of the conventional or modified paver placed surface treatment, the Contractor shall abrade the existing pavement markings so that at least 75% of the glass beads in the existing pavement markings are removed. The method of abrading may include sand blasting, water blasting, grinding, or other method approved by the Engineer or Authorized User Representative. Care shall be taken to avoid damage to passing traffic. All damage to passing traffic caused by the Contractor 's operations shall be the Contractor 's responsibility. Traffic will be controlled by the Authorized User.

Payment will be made by the linear foot of pavement marking 4-inches wide. Payment for pavement markings wider than 4-inches or for pavement marking symbols will be made by the following method:

$$\frac{\text{Width of marking (inches)} \times \text{Linear Feet}}{4\text{-inches}}$$

The price bid for pavement marking abrading shall include all labor, materials, and equipment required to abrade the existing pavement markings to the satisfaction of the Engineer or Authorized User Representative.

**6.15.6 Abrading Existing Pavement Markings with Work Zone Traffic Control by the Contractor**

If the Contractor, with the concurrence of the Resident Engineer or Authorized User Representative, determines that it is necessary for the performance of the conventional or modified paver placed surface treatment, the Contractor shall abrade the existing pavement markings so that at least 75% of the glass beads in the existing pavement markings are removed. The method of abrading may include sand blasting, water blasting, grinding, or other methods approved by the Engineer or Authorized User Representative. Care shall be taken to avoid damage to passing traffic. All damage to passing traffic caused by the Contractor 's operations shall be the Contractor 's responsibility. Traffic will be controlled by the Contractor.

LOT 6: PAVER PLACED SURFACE TREATMENT – CONVENTIONAL & MODIFIED  
(Cont'd)

The Contractor shall place temporary pavement markings as specified elsewhere in this Invitation for Bids under optional work zone traffic control, unless the conventional or modified paver placed surface treatment will be placed the same day as pavement markings are abraded. During the pavement markings abrading operation, traffic will be controlled by the Contractor in accordance with the MUTCD. The Contractor shall submit a proposed Traffic Control Plan to the Engineer or Authorized User Representative for approval. The plan may be based on the Work Zone Traffic Control included in this Invitation for Bids see Attachment 14 – *NYSDOT Work Zone Traffic Control*.

Payment will be made by the linear yard of pavement marking 4-inches wide. Payment for pavement markings wider than 4-inches or for pavement marking symbols will be made by the following method:

$$\frac{\text{Width of marking (inches)} \times \text{Linear Feet}}{4\text{-inches}}$$

The price bid for pavement marking abrading shall include all labor, materials, and equipment required to abrade the existing pavement markings and to properly control traffic to the satisfaction of the Engineer or Authorized User Representative.

**6.15.7 Special Note: Work Zone Intrusion Initiative**

As part of the Department of Transportation's Work Zone Intrusion Initiative, the following countermeasures shall apply to this Invitation for Bids:

**Channelizing Device Spacing Reduction**

A maximum channelizing device spacing of 40-feet shall be provided at stationary work sites where workers are exposed to traffic. This spacing shall be maintained a reasonable distance upstream of workers and shall be used throughout the work zone.

Where tapers are located less than 500-feet from the work site (1,000-feet for high speeds) the 40-foot spacing shall be used in the taper as well.

Drums or vertical panels are preferred for long-term and intermediate term stationary work zones, and at any locations where the risk of intrusion is high. Traffic cones are normally adequate for work zones set up and removed on a daily basis.

In long lane or shoulder closures, at least two channelizing devices shall be placed transversely at maximum 800-foot intervals to discourage traffic from driving through the closed lane. **Transversely placed devices are not required where pilot cars are in use.**

Frequent checks shall be made to reset channelizing devices dislodged by traffic.

**Flagger Station Enhanced Setups**

Additional cones and a flag tree meeting the requirements of Section 6F.62 of the MUTCD shall be used upstream of flagger stations to provide added warning to drivers. These devices shall be used for flagger stations except those that are constantly moving or are in use at one location or no more than a few minutes. If the W20-7a Flagger sign is used, the additional cones and flag tree shall also be used.

For additional details on Flagger Enhanced Setups, see Attachment 14 – *NYSDOT Work Zone Traffic Control* included in this Invitation for Bids.

**6.16 Detailed Specifications – Paver Placed Surface Treatment (Conventional and Modified)**

Please, see Attachment 11 – *Detailed Specifications – Liquid Bituminous Materials*.

**LOT 7: JOINT AND CRACK FILLER/SEALER, AND MASTIC REPAIR MATERIAL**

**7.1 Introduction**

Joint and Crack Filler/Sealers and mastics are hot-poured liquid bituminous materials used to fill and/or seal cracks in the surface of highway pavements. Some products incorporate recycled materials with up to 18% recycled content and up to 18% post-consumer content.

**7.2 Pricing Information**

**7.2.1 General**

Price quoted shall be to three (3) decimal places.

Price quoted shall be net, F.O.B. per gallon, per pound, or per linear foot for each material item, per 1/4 hour for excess time, per day per additional flagger, and per day per optional pilot vehicle with driver, as indicated in the Invitation for Bids. Price adjustments, if any, will be calculated on the basis of the material actually furnished.

The price (mile and gallon/pound range) for a specific job will be calculated at the same rate. This rate will be determined by finding the one category which applies to the total miles and gallons/pounds per job.

For example, a job which is 21 miles from the plant will be calculated at the same rate per gallon for each mile (from 1 to 21) which is indicated in the 11-25 miles column herein, rather than on a cumulative basis. Similarly, a job which is 39 miles from the plant and requires 420 gallons over a two-day period will be calculated using the 26-50 miles column and the 151-300 gallons range since it is presumed that equal quantities are to be applied each day.

**Option 1: (Per Gallon)**

Heat, Haul, Deliver WITH Contractor's Operator to the locations in a hot oil heated, containerized, mobile tank. Traffic control and supervision to be supplied by the Authorized User.

**“Option 2: (Per Gallon) Traditional Overband Application Method**

Heat, Haul, Deliver (in hot oil-heated, containerized, mobile tanks) and APPLY WITH Contractor's Operators who will operate equipment, clean cracks and apply material at the locations. Traffic control and supervision are to be supplied by the Authorized User or by the Contractor under the Optional Work Zone Traffic Control section of this Invitation for Bids. Detailed Specifications can be found elsewhere in this Invitation for Bids (Attachment 11 - *Detailed Specifications – Liquid Bituminous Materials*) under CLEANING AND SEALING CRACKS IN ASPHALT PAVEMENT.

**Option 3: (Per Linear Foot) Rout, Clean & Seal Application Method - ASTM D6690 Type II only**

Heat, Haul, Deliver (in hot oil-heated, containerized, mobile tanks), rout, clean cracks, and seal cracks at the locations. Traffic control and supervision are to be supplied by the Authorized User or by the Contractor under the Optional Work Zone Traffic Control section of this Invitation for Bids.

Detailed Specifications can be found elsewhere in this Invitation for Bids (Attachment 11 - *Detailed Specifications – Liquid Bituminous Materials*) under ROUTING, CLEANING AND SEALING CRACKS IN ASPHALT PAVEMENT USING HOT APPLIED SEALANT.

**Option 4: (Per Pound) Plastic Joint Material (ASTM D6690 Type II)**

Deliver 6690 Type II.

The minimum delivery quantity shall be one (1) ton.

Detailed Specifications can be found elsewhere in this Invitation for Bids (Attachment 11 - *Detailed Specifications – Liquid Bituminous Materials*) under PLASTIC JOINT MATERIAL (ASTM 6690 Type II).

**Option 5: (Per Pound) Plastic Joint Material (ASTM D6690 Type II)**

Material price (Pick-up only).

Detailed Specifications can be found elsewhere in this Invitation for Bids (Attachment 11 - *Detailed Specifications – Liquid Bituminous Materials*) under PLASTIC JOINT MATERIAL (ASTM 6690 Type II).

LOT 7: JOINT AND CRACK FILLER/SEALER, AND MASTIC REPAIR MATERIAL  
(Cont'd)

**Option 6: (Per Pound) Wide Joint/Crack and Spall Repairs Using Hot Applied Aggregate Reinforced Mastic Material**

Heat, Haul, Deliver (in hot oil-heated, containerized, mobile tanks), and APPLY WITH Contractor's Operators who will operate equipment, clean cracks and apply material at the locations. Traffic control and supervision are to be supplied by the Authorized User or by the Contractor under the Optional Work Zone Traffic Control section of this Invitation for Bids.

Detailed Specifications can be found elsewhere in this Invitation for Bids (Attachment 11 - *Detailed Specifications – Liquid Bituminous Materials*) under WIDE JOINT/CRACK AND SPALL REPAIRS USING HOT APPLIED AGGREGATE REINFORCED MASTIC MATERIAL.

**Option 7: (Per Pound) Wide Joint/Crack and Spall Repairs Using Hot Applied Aggregate Reinforced Mastic Material**

Deliver Mastic Material.

The minimum delivery quantity shall be one (1) ton.

Detailed Specifications can be found elsewhere in this Invitation for Bids (Attachment 11 - *Detailed Specifications – Liquid Bituminous Materials*) under WIDE JOINT/CRACK AND SPALL REPAIRS USING HOT APPLIED AGGREGATE REINFORCED MASTIC MATERIAL.

**Option 8: (Per Pound) Wide Joint/Crack and Spall Repairs Using Hot Applied Aggregate Reinforced Mastic Material**

Material Price (pickup only).

Detailed specifications can be found elsewhere in this Invitation for Bids (Attachment 11 - *Detailed Specifications – Liquid Bituminous Materials*) under WIDE JOINT/CRACK AND SPALL REPAIRS USING HOT APPLIED AGGREGATE REINFORCED MASTIC MATERIAL.

**Work Zone Traffic Control**

Price quoted for Work Zone Traffic Control shall be net per gallon, pound, or linear foot.

**Additional Flagger(s)**

Price quoted for Additional Flagger(s) (if required) shall be net per day (to the nearest quarter day) for additional flagger(s).

**Pilot Vehicle(s) With Driver(s)**

Price quoted for Pilot Vehicle(s) with Driver(s) shall be net per day per vehicle with driver.

**Time Rate**

Price quoted for charge for time for each 15 minutes or portion thereof waiting time. Once work has commenced, no further time rate charge is allowed. Time Rate does not apply to Diluted, Straight and Non-Tracking tack coats.

**Note:** Price bid, with the exception of Options 5 and 8, must include material and delivery charges per options as indicated.

**7.2.2 Insurance**

Please refer to Section 6.19 - Insurance of the Invitation for Bids for information about insurance.

LOT 7: JOINT AND CRACK FILLER/SEALER, AND MASTIC REPAIR MATERIAL  
(Cont'd)

7.3 Asphalt Price Adjustments – Joint and Crack Filler/Sealer and Mastic Repair Material

7.3.1 General

- a. Asphalt price adjustments allowed will be based on the November 1, 2025 average of the F.O.B. terminal price per ton of unmodified PG 64S-22 binder without anti-stripping agent (base average F.O.B. terminal price). The new monthly average terminal price will be determined by the New York State Department of Transportation based on prices of pre-approved primary sources of performance graded binder in accordance with the New York State Department of Transportation Standard Specification.

**The November 1, 2025 average is \$638.000**

**NOTE:** The same grade of asphalt cement used in establishing the base average F.O.B. terminal price shall be used in establishing the new average F.O.B. terminal price.

In the event that one or more of the New York State Department of Transportation pre-approved sources discontinue posting a price for asphalt cement, the base average F.O.B. terminal **price shall not be recalculated.**

- b. The new average F.O.B. terminal price will be determined based on the above F.O.B. terminal prices posted each month during the contract period. However, asphalt price adjustments, in accordance with the formula below, will be effective for deliveries made on and after the first of the month following the adjustment date.
- c. The unit prices of bituminous materials purchased from any award based on this specification will be subject to adjustment based on the following formula:

For Crack Sealing:

Price Adjustment (per gallon)	=	$\frac{\text{New Monthly Average FOB Terminal Price} - \text{Base Average Terminal Price}}{235}$	X	Total Allowable Petroleum %
----------------------------------	---	--	---	-----------------------------

For Mastic Materials:

Price Adjustment (per pound)	=	$\frac{\text{New Monthly Average FOB Terminal Price} - \text{Base Average Terminal Price}}{2000}$	X	Total Allowable Petroleum %
---------------------------------	---	---	---	-----------------------------

For Routing, Cleaning and Sealing:

Price Adjustment (per linear foot)	=	$\frac{\text{New Monthly Average FOB Terminal Price} - \text{Base Average Terminal Price}}{14,400}$	X	Total Allowable Petroleum %
---------------------------------------	---	---	---	-----------------------------

Positive Price Adjustment number shall be added to original per gallon/pound/linear foot Bid Price.  
Negative Price Adjustment number shall be subtracted from original per gallon/pound/linear foot Bid Price.

**New Monthly Average F.O.B. Terminal Price**

The average F.O.B. terminal price for unmodified PG 64S-22 binder without anti-stripping agent is as determined by the New York State Department of Transportation per New York State Department of Transportation Standard Specification.

LOT 7: JOINT AND CRACK FILLER/SEALER, AND MASTIC REPAIR MATERIAL  
(Cont'd)

**Base Average F.O.B. Terminal Price**

The average F.O.B. terminal price of unmodified PG 64S-22 binder without anti-stripping agent is as determined by the New York State Department of Transportation as of November 1, 2025.

**Total Allowable Petroleum**

The percentage of total allowable petroleum for each item is as follows:

Material Designation	Asphalt %	Petroleum Allowance %	Total Allowable Petroleum %
ASTM D6690 Type II	56.0	0.2	56.2%
Mastic Material	40.0	0.2	40.2%

Asphalt Price Adjustments will not be allowed for materials which do not have an asphalt cement base.

- d. Work performed after the expiration of the contract, where no extension has been granted, resultant from purchase orders placed prior to expiration of the contract will be based on the new average for the month in which the work is done applying the same base established for that contract.  
Asphalt Price Adjustments for any contracts that are extended will be based on the new average for the month in which the work is done applying the same base established for that contract.
- e. Asphalt Price Adjustments allowed by this contract shall be calculated and applied to the original prices. There will not be Asphalt Price Adjustments unless the change amounts to more than \$0.010 per gallon/\$0.001 per lb./\$0.002 per linear foot as applicable from the original price. In these instances, prices will revert back to the original prices.
- f. All Asphalt Price Adjustments will be computed to three decimal places.
- g. Should these provisions result in a price structure which becomes unworkable, detrimental or injurious to the State or in prices which are not truly reflective of market conditions or which are deemed by the Commissioner to be unreasonable or excessive, and no adjustment in price is mutually agreeable, the Commissioner reserves the sole right upon ten days written notice mailed to the Contractor to terminate any contract resulting from this bid opening.
- h. All Asphalt Price Adjustments shall be published by the State and issued to all contract holders whose responsibility will be to attach the appropriate State notification (based on when the work was performed) to the payment invoice submitted to the Authorized User.

**7.3.2 Asphalt Price Adjustment – Joint and Crack Filler/Sealer: Example**

This example is for illustration purposes only. Actual Base Average Price, etc., may vary.

Item D6690 Type II

Base Average Price = \$638.000

New Average Price = \$648.000

% Total Allowable Petroleum = 56.2 %

$$\boxed{\begin{array}{c} \text{Price} \\ \text{Adjustment} \\ \text{(per gallon)} \end{array}} = \boxed{\frac{(648.000 - 638.000)}{235}} \times \boxed{0.562}$$

$$\boxed{\begin{array}{c} \text{Price} \\ \text{Adjustment} \\ \text{(per gallon)} \end{array}} = \boxed{0.024 \text{ per gallon}}$$

LOT 7: JOINT AND CRACK FILLER/SEALER, AND MASTIC REPAIR MATERIAL  
(Cont'd)

**7.4 Minimum Order**

The absolute minimum order is 100 gallons for Material Grade Options 1-2, 1,000 linear feet per day for Option 3, and 1000 pounds for Option 6.

**7.5 Delivery Ticket**

A delivery ticket shall be provided with each load of crack filler/sealer stating the following:

1. Storage facility identification
2. Ticket Number
3. Date/time
4. Item Number and Type
5. Quantity

**NOTE:** Although the delivery ticket for joint filler and mastics is not required to state the quantity delivered in 60°F gallons, payment will be made for 60°F gallons.

**7.6 Payment**

Payment shall be made at contract price per gallon, per pound, excess time rate, or linear foot for the actual quantities of crack filler/sealer furnished to and verified by the Authorized User. This determination as to quantities involved in any contract shall be accepted as final and binding upon the Contractor. A delivery slip stating quantities shall accompany each shipment. An invoice shall be sent promptly by the Contractor to the Engineer of the Region or to the Authorized User placing the order. Measurement shall be based on the volume of crack filler/sealer at a temperature of 60°F. The method to be used for volume corrections shall be the method and coefficients of expansion given in the “Standard Petroleum Tables, A.S.T.M. D1250”. The price per unit for other than “Specific Projects” arrived at (mutually estimated) by the Contractor and the Authorized User on the Price Calculation Worksheet or the price per unit resultant from the actual average daily production, whichever is less, shall be the price per unit paid to the Contractor. No additional payment shall be due the Contractor for production rates that are not equal to the rate upon which the calculation work sheet price was based.

**7.7 Work Hours**

Work will not be permitted on Sundays and Holidays. If the Contractor desires to work overtime on other days, dispensation from the NYS Labor Department must be obtained using Department of Labor Form PW-30.

**7.8 Optional Work Zone Traffic Control**

The Contractor shall submit per gallon or per linear foot prices for Work Zone Traffic Control for the various options and quantity ranges as indicated on the bid sheets as prescribed by this specification. When requesting price quotations from the Contractors, the Authorized User may at their option, include Work Zone Traffic Control by the Contractor for the specific project anticipated.

If optional work zone traffic control is included in the quick quoting process, the Contractor shall be responsible for Work Zone Traffic Control. Traffic shall be controlled in accordance with the Manual of Uniform Traffic Control Devices (MUTCD) and Sections 619-1 through 619-3 of the Standard Specifications including modifications to the Standard Specifications. The Contractor shall submit a Work Zone Traffic Control Plan for approval to the Resident Engineer at the Pre-Crack Sealing Meeting. For two-way roadways, NYSDOT 619 Standard Sheets 619-307, 619-308, 619-309, 619-312 and 619-314 may be used as a basis for development of a Work Zone Traffic Control Plan. For one-way roadways, NYSDOT 619 Standard Sheets 619-302, 619-303, and 619-313 may be used as a basis for development of a Work Zone Traffic Control Plan. For one-way Freeways or Expressways, NYSDOT 619 Standard Sheets 619-301, 619-302, 619-304, and 619-305 may be used as a basis for development of a Work Zone Traffic Control Plan. A link to NYSDOT 619 Standard Sheets can be found on Attachment 14 – *NYSDOT Work Zone Traffic Control* included within this Invitation for Bids.

**LOT 7: JOINT AND CRACK FILLER/SEALER, AND MASTIC REPAIR MATERIAL  
(Cont'd)**

All necessary flaggers for Work Zone Traffic Control shall be provided by the Contractor. For two-way roadways, a minimum of three flaggers shall be provided while the crack/joint sealing/filling operation is underway. One shall be stationed at each end of the operation, and one shall be stationed with the crack sealant melting unit. For one-way roadways, a minimum of two flaggers shall be provided while the crack/joint sealing/filling operation is underway. One shall be stationed at the beginning of the operation, and one shall be stationed with the operator. The Contractor shall station flaggers such that communication is maintained between flaggers. Hand signals, radios, pilot vehicles or some other means of communication may be used subject to the approval of the Resident Engineer or Authorized User Representative.

The Contractor shall provide construction signs as specified in Section 619-1 through 619-3 of the Standard Specifications and in the MUTCD. At a minimum the Contractor shall install the construction signs indicated in their Work Zone Traffic Control Plan or as shown on the Work Zone Traffic Control included in this Invitation for Bids see Attachment 14 – *NYSDOT Work Zone Traffic Control*.

On major intersecting roads, the Contractor shall place ROAD WORK 500 FT. or ROAD WORK AHEAD signs (W20-1, 36" X 36") 300 to 500 feet in advance of the main line. Major intersecting roads are defined as State, County, Town, Village, or City roads. The Contractor may provide Portable signs as shown in Figure 6F-2 for lane closures during work hours.

All costs for Work Zone Traffic Control including flagging, pavement delineation, and construction signs are to be included in the prices bid per gallon or per linear foot.

**7.8.1 Additional Flaggers for Work Zone Traffic Control**

If the Engineer or Authorized User Representative determines that more than three (3) flaggers are necessary to properly control traffic on two-way roadways or more than two (2) flaggers are necessary to properly control traffic on one-way roadways and the Contractor is responsible for Work Zone Traffic Control under this Invitation for Bids, the Contractor shall provide additional flaggers under the Additional Flaggers item. The price bid per flagger per day shall include all costs of providing a flagger where directed by the Engineer or Authorized User Representative with all the necessary safety equipment, i.e. stop/slow paddle, flag, vest, hardhat, etc. Price quoted shall be by the day for each flagger provided. A day shall be determined as including the time period between the commencement and completion of work on any calendar day (standard eight-hour day). No extra payment shall be provided if the Contractor elects to work a longer day than the standard eight-hour workday. Payment shall be made to the nearest quarter day as determined by the Engineer or Authorized User Representative.

**7.8.2 Optional Pilot Vehicles with Drivers**

If the Contractor is responsible for Work Zone Traffic Control and required by the Engineer or Authorized User Representative, the Contractor shall provide sufficient two-way radio equipped pilot vehicles with drivers to guide traffic around the crack sealing work zone at a maximum of 15 miles per hour. Price quoted shall be by the day for each pilot vehicle with driver provided. A day shall be determined as including the time period between the commencement and completion of work on any calendar day (standard eight-hour day). No extra payment shall be provided if the Contractor elects to work a longer day than the standard eight-hour workday. Payment shall be made to the nearest quarter day as determined by the Engineer or Authorized User Representative.

The pilot vehicles shall be equipped with construction signs meeting the requirements of Section 6F.58 of the MUTCD and a rotating amber beacon:

Sign	Minimum Size	Location
PILOT CAR FOLLOW ME	G20-4 Conventional 36" x 18"	On the back of the pilot vehicle.

The pilot vehicle shall have the name of the Contractor prominently displayed.

LOT 7: JOINT AND CRACK FILLER/SEALER, AND MASTIC REPAIR MATERIAL  
(Cont'd)

**7.8.3 Special Note: Work Zone Intrusion Initiative**

As part of the Department of Transportation's Work Zone Intrusion Initiative, the following countermeasures shall apply to this Invitation for Bids:

**Channelizing Device Spacing Reduction**

A maximum channelizing device spacing of 40-feet shall be provided at stationary work sites where workers are exposed to traffic. This spacing shall be maintained a reasonable distance upstream of workers and shall be used throughout the work zone.

Where tapers are located less than 500-feet from the work site the 40-foot spacing shall be used in the taper as well.

Drums or vertical panels are preferred for long-term stationary and intermediate-term stationary work zones, and at any locations where the risk of intrusion is high. Traffic cones are normally adequate for work zones set up and removed on a daily basis.

In long lane or shoulder closures, at least two channelizing devices shall be placed transversely at maximum 800-foot intervals to discourage traffic from driving through the closed lane. **Transversely placed devices are not required where pilot cars are in use.**

Frequent checks shall be made to reset channelizing devices dislodged by traffic.

**Flagger Station Enhanced Setups**

Additional cones and a flag tree meeting section 6F.62 of the MUTCD shall be used upstream of flagger stations to provide added warning to drivers. These devices shall be used for flagger stations except those that are constantly moving or are in use at one location for no more than a few minutes. If the W20-7a Flagger sign is required, the additional cones and flag tree shall also be used.

For additional details on Flagger Station Enhanced Setups, see Attachment 14 – *NYS DOT Work Zone Traffic Control* included in this Invitation for Bids.

**7.9 Detailed Specifications – Joint and Crack Filler/Sealer and Mastics**

Please, see Attachment 11 – *Detailed Specifications – Liquid Bituminous Materials*.