

Group #37829 IFB #23055 - Attachment 08: Nucor Steel, Marion Inc.

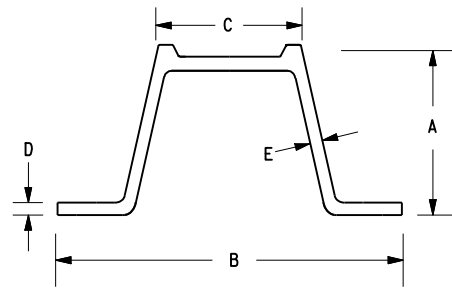

POST SIZE	AREA (in ²)	I (in ⁴)	S (in ³)	A	B	C	D	E	MOMENT*
2.00 lb/ft	0.56	0.16	0.20	1.462	3.062	1.278	0.122	0.105	1092 ft-lbs
2.50 lb/ft	0.70	0.21	0.25	1.516	3.062	1.278	0.176	0.117	1394 ft-lbs
2.75 lb/ft	0.76	0.23	0.27	1.536	3.062	1.278	0.196	0.121	1512 ft-lbs
3.00 lb/ft	0.84	0.38	0.34	1.881	3.500	1.336	0.185	0.126	1904 ft-lbs
4.00 lb/ft	1.11	0.47	0.47	1.968	3.500	1.336	0.272	0.143	2615 ft-lbs

*REDUCE MOMENT CAPACITY BY 25% TO ACCOUNT FOR TORSION EFFECTS IN OPEN CROSS-SECTION SINGLE POST INSTALLATIONS.

POSTS SHALL BE PRODUCED FROM HIGH STRENGTH BILLET STEEL, GRADE 80-SP. CHEMICAL PROPERTIES OF THE STEEL SHALL CONFORM TO ASTM A-1 AND PHYSICAL PROPERTIES SHALL CONFORM TO ASTM A-499 (SEE TABLE 1).

SIGN POSTS SHALL BE PUNCHED THEIR FULL LENGTH WITH 3/8" Ø HOLES ON 1" CENTERS.

BASE POSTS SHALL BE PUNCHED WITH A MINIMUM OF THIRTY-SIX 3/8" Ø HOLES ON 1" CENTERS (TO ACCOMMODATE OPTIONAL SOIL PLATE) WITH THE FIRST HOLE 1" FROM THE TOP.

BASE POSTS SHALL BE DRIVEN TO 38" MINIMUM EMBEDMENT (SEE TABLE 2); A MAXIMUM OF 4" MAY PROTRUDE ABOVE THE SURROUNDING GROUND SURFACE.

POSTS SHALL BE HOT-DIP GALVANIZED AFTER FABRICATION IN ACCORDANCE WITH ASTM A-123.

SPLICE HARDWARE SHALL BE AS SUPPLIED OR RECOMMENDED BY THE MANUFACTURER, EITHER ZINC-PLATED PER ASTM B-633 (MINIMUM 0.315 MIL COATING THICKNESS) OR CADMIUM PLATED ACCORDING TO ASTM B-766 (CLASS B).

ALL GALVANIZING AND GALVANIZING REPAIRS SHALL BE DONE IN ACCORDANCE WITH §719-01, TYPE III.

AN S-1 SOIL CONDITION SHOULD BE ASSUMED. S-1 INCLUDES SANDS, GRAVELS AND SILTS (AND THEIR MIXTURES) WHICH EXHIBIT PENETRATION VALUES OF 9 OR MORE BLOWS PER FOOT USING A STANDARD 300 LB. DROP HAMMER AND AN 18 INCH FALL. SHOULDER MATERIALS ARE INCLUDED IN THIS CATEGORY.

S-2 INCLUDES UNIFORM SANDS WHICH EXHIBIT PENETRATION VALUES OF LESS THAN 9 BLOWS PER FOOT USING A 300 LB. DROP HAMMER. BEACH SANDS ARE INCLUDED IN THIS CATEGORY

THE GEOTECHNICAL ENGINEERING BUREAU AND THE STRUCTURES DIVISION SHOULD BE CONTACTED WHEN A POST IS TO BE PLACED IN A PLASTIC (SOFT CLAY OR ORGANIC) DEPOSIT, OR WHEN THE GROUNDWATER ELEVATION IS WITHIN THE MINIMUM EMBEDMENT.

LAP SPLICE NUTS AND BOLTS SHALL BE M180, WITH AN ULTIMATE TENSILE STRENGTH OF 180 KSI, MIN.

BASE POSTS DAMAGED OR DEFORMED IN THE SPLICE CONTACT AREA SHALL BE REPAIRED OR REPLACED A.O.B.E. AT NO ADDITIONAL COST TO THE STATE. DRIVE CAPS ARE REQUIRED.

EMBEDMENT TYPE	SOIL SLOPE	SOIL DESCRIPTION					
		S - 1 NON-PLASTIC (MED TO VERY COMPACT)			S - 2 NON-PLASTIC (LOOSE TO VERY LOOSE)		
		MAX NO. OF POSTS	MIN. EMBEDMENT	SOIL ρ	MAX NO. OF POSTS	MIN. EMBEDMENT	SOIL ρ
LAP-SPLICE	FLAT	3	38	NO	3	60	YES
	MODERATE	3	54	NO	3	60	YES
	STEEP	3	60	NO	3	60	YES

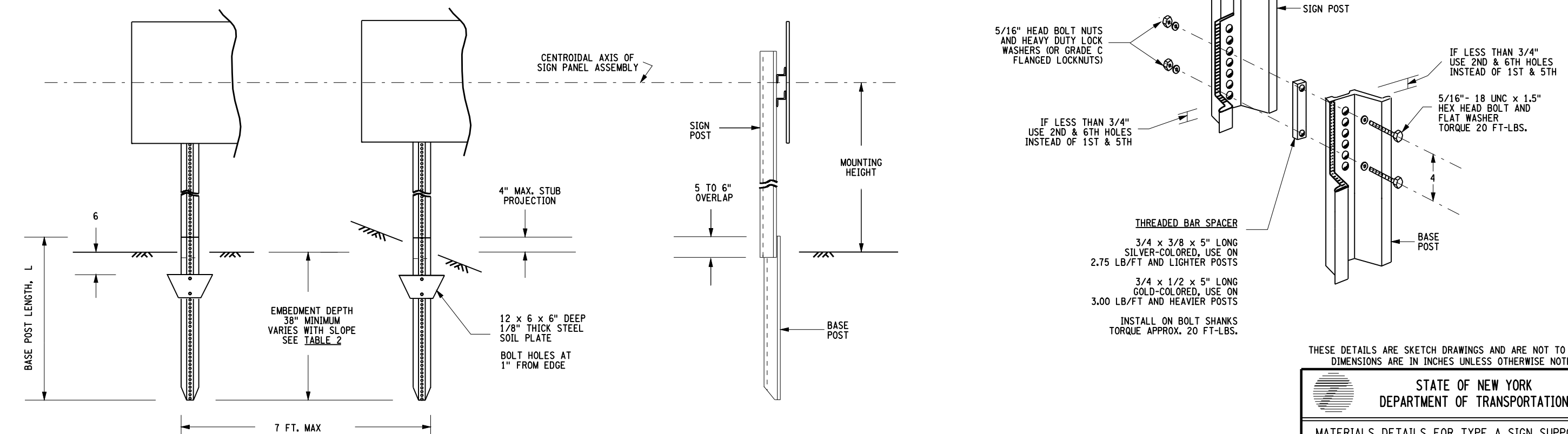
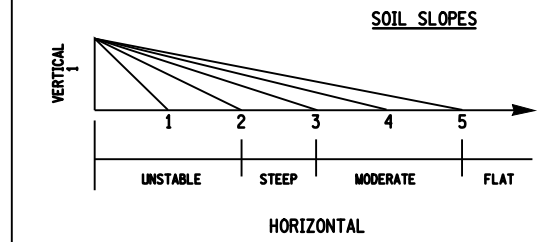

EMBEDMENT DETAILS

NOTE: THREE POSTS ALLOWED WITHIN 7 FT SWATH

THESE DETAILS ARE SKETCH DRAWINGS AND ARE NOT TO SCALE
DIMENSIONS ARE IN INCHES UNLESS OTHERWISE NOTED

 STATE OF NEW YORK DEPARTMENT OF TRANSPORTATION	
MATERIALS DETAILS FOR TYPE A SIGN SUPPORTS	
NUCOR STEEL, MARION INC. U CHANNEL SIGN SUPPORTS STANDARD CAPACITY	
SHEET 1 OF 4	
ISSUED UNDER EB 06-021 EFFECTIVE: 05/02/2006 REVISION:	MD645E-MRB-01

FILE NAME = IP-PWP\dms61672\MARION.L.E.STD1.SHEET1.DGN
 DATE/TIME = 05-MAY-2006 14:21
 USER = of-ank

Group #37829 IFB #23055 - Attachment 08: Nucor Steel, Marion Inc.

SINGLE POST

60 MPH WIND SPEED

70 MPH WIND SPEED

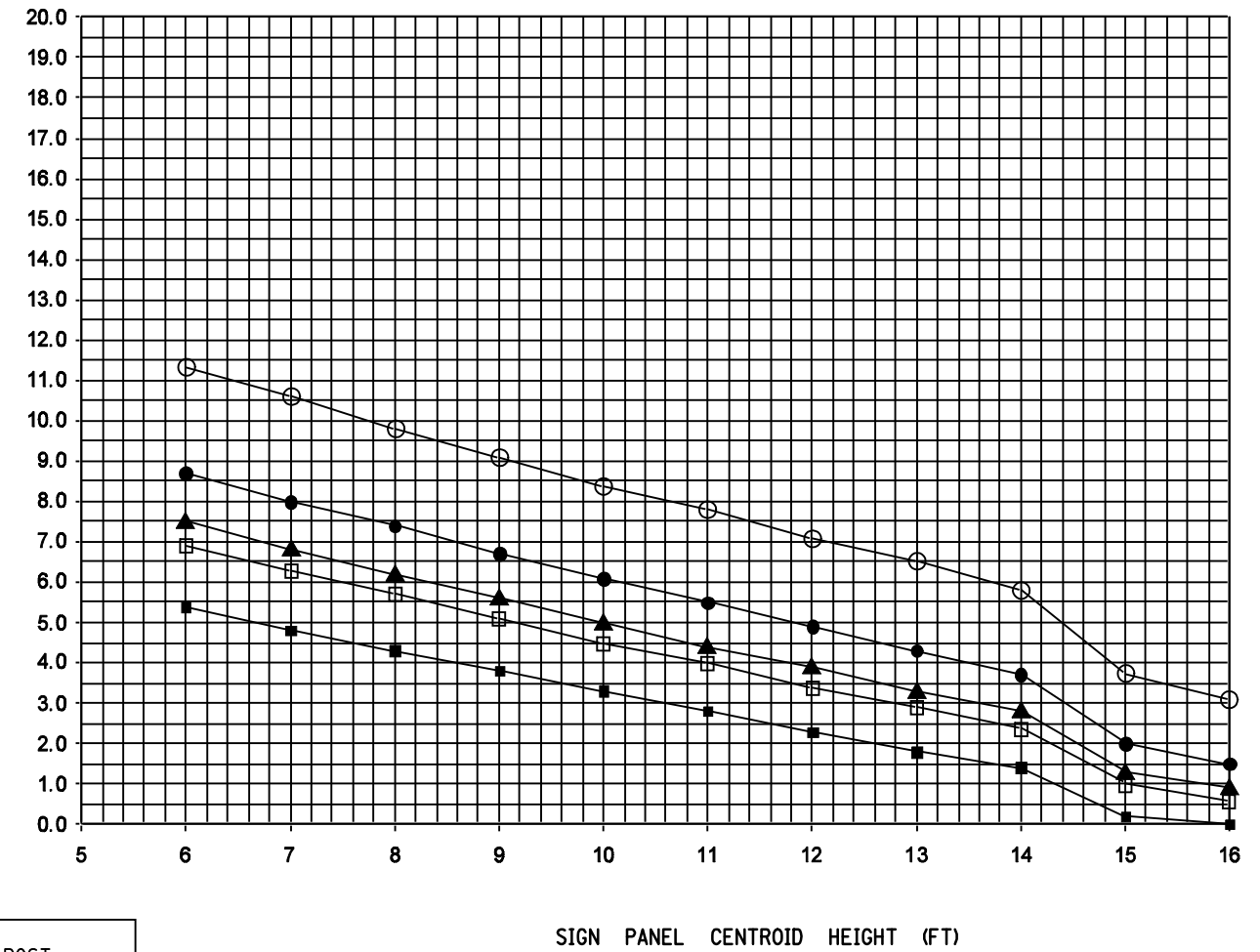
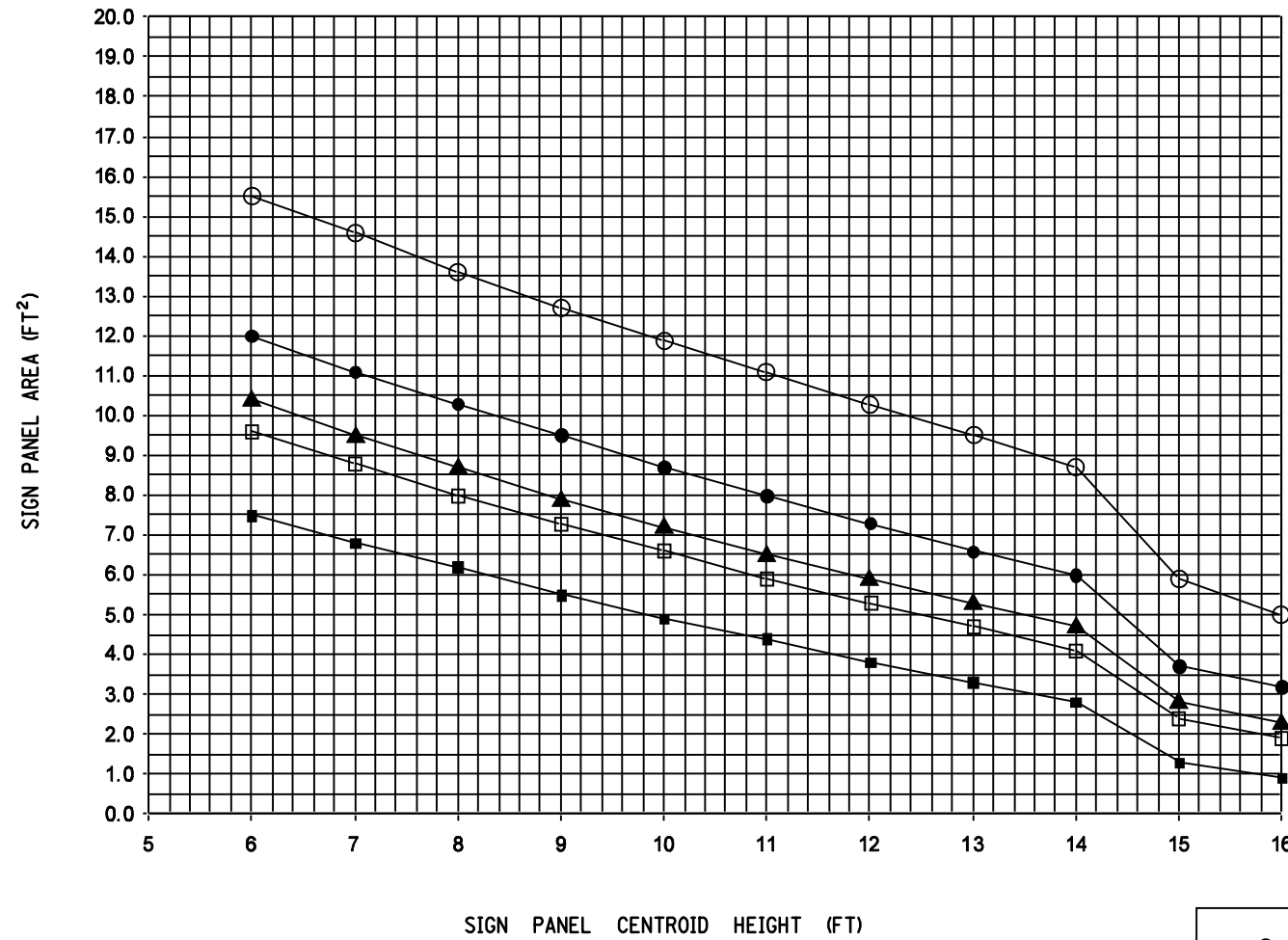

- 4.00 lb/ft POST
- 3.00 lb/ft POST
- ▲ 2.75 lb/ft POST
- ◻ 2.50 lb/ft POST
- 2.00 lb/ft POST

CAUTION : ALLOWABLE SIGN PANEL AREAS ARE CALCULATED ASSUMING SITE ELEVATIONS CLOSE TO THE SURROUNDING TERRAIN.
 FOR ELEVATED SITE CONDITIONS (E.G. OVERPASSES, HIGH CONTOUR AREAS) WHERE THE INFLUENCE OF THE GROUND ON THE WIND IS REDUCED, ALLOWABLE SIGN PANEL AREAS MUST BE REDUCED (AS MUCH AS 40%) ACCORDING TO THE AASHTO "STANDARD SPECIFICATIONS FOR STRUCTURAL SUPPORTS FOR HIGHWAY SIGNS, LUMINAIRES AND TRAFFIC SIGNALS", UNDER THE SECTION "LOADS".
 USE AN INCREASED WIND PRESSURE FOR SIGN PANEL CENTROID HEIGHTS 29.0 FT OR MORE ABOVE THE SURROUNDING TERRAIN, AS FOLLOWS:
 ZONE A (REGIONS 1,2,6,8 AND 9): 20.4 PSF
 ZONE B (REGIONS 3,4,5,7,10 AND 11): 27.6 PSF

THESE DETAILS ARE SKETCH DRAWINGS AND ARE NOT TO SCALE
 DIMENSIONS ARE IN INCHES UNLESS OTHERWISE NOTED

STATE OF NEW YORK DEPARTMENT OF TRANSPORTATION	
MATERIALS DETAILS FOR TYPE A SIGN SUPPORTS	
NUCOR STEEL, MARION INC. U CHANNEL SIGN SUPPORTS STANDARD CAPACITY	
SHEET 2 OF 4	
ISSUED UNDER EB 06-021 EFFECTIVE: 05/02/2006 REVISION:	MD645E-MRB-02

FILE NAME = IP_PWPdms61672\MARION.E.STD1.SHEET2.DGN
 DATE/TIME = 05-MAY-2006 14:21
 USER = ofr-ank

Group #37829 IFB #23055 - Attachment 08: Nucor Steel, Marion Inc.

60 MPH WIND ZONE

DOUBLE POST

TRIPLE POST

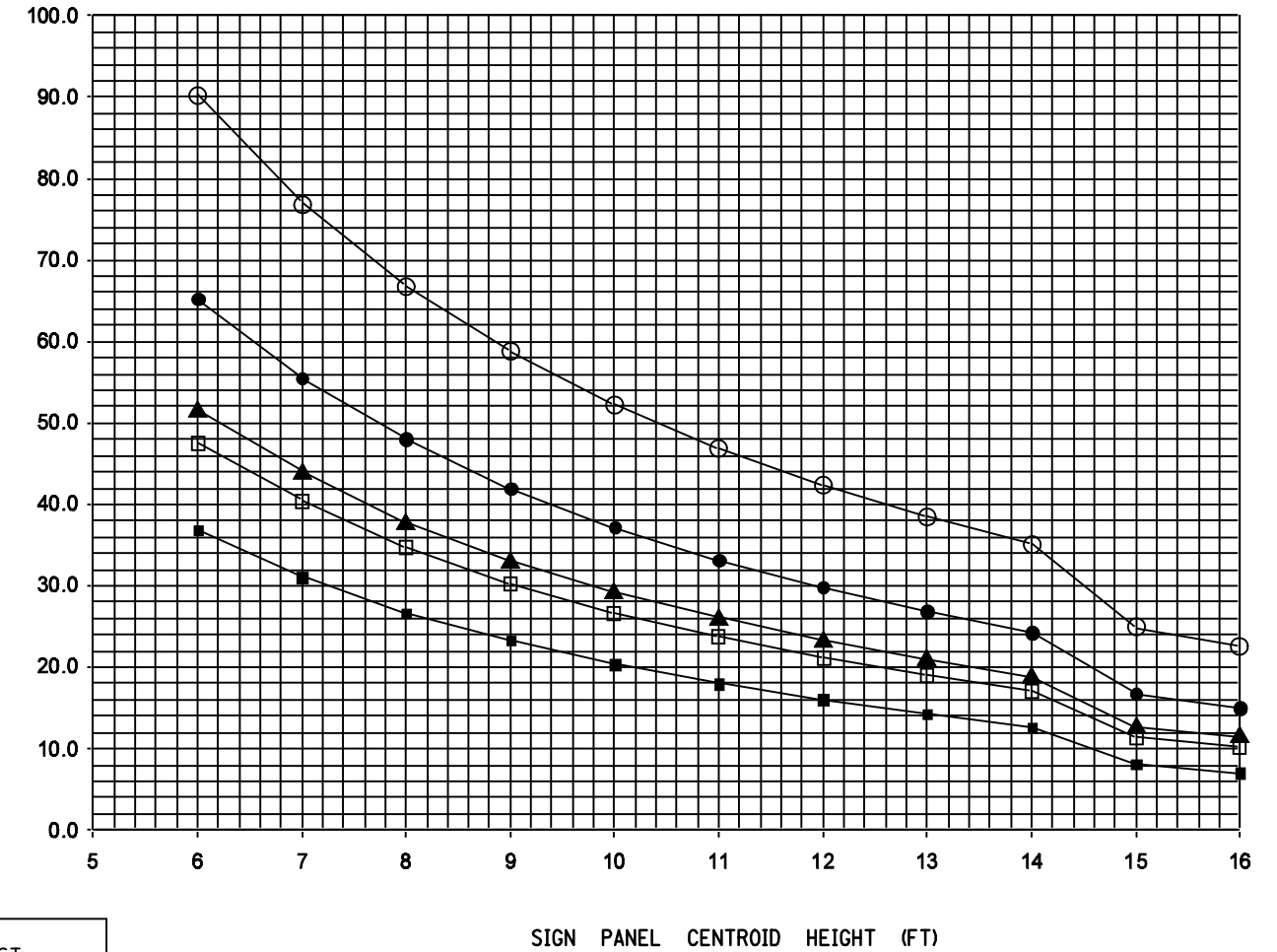
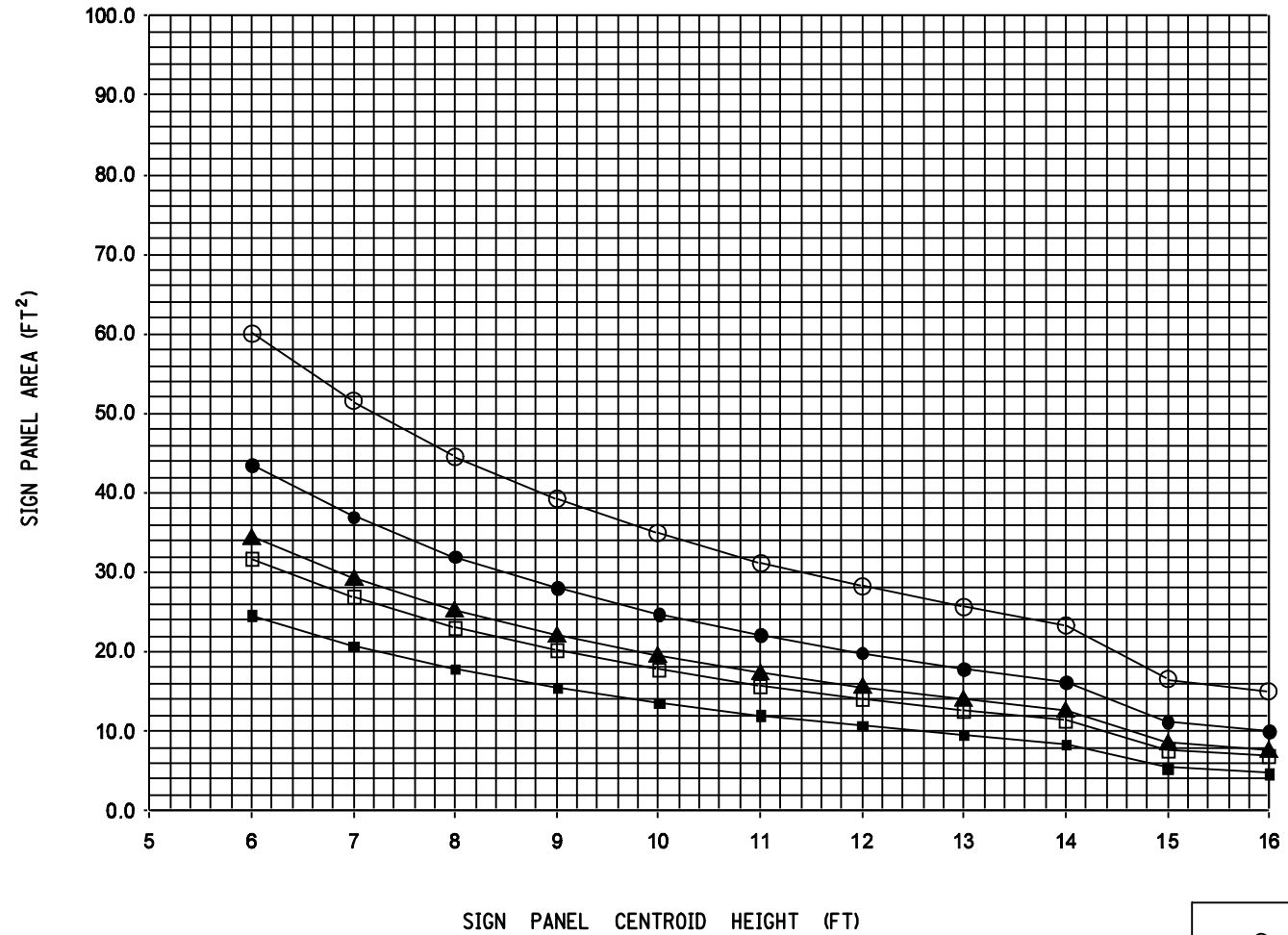

- 4.00 lb/ft POST
- 3.00 lb/ft POST
- ▲ 2.75 lb/ft POST
- ◻ 2.50 lb/ft POST
- 2.00 lb/ft POST

CAUTION : ALLOWABLE SIGN PANEL AREAS ARE CALCULATED ASSUMING SITE ELEVATIONS CLOSE TO THE SURROUNDING TERRAIN.
 FOR ELEVATED SITE CONDITIONS (E.G. OVERPASSES, HIGH CONTOUR AREAS) WHERE THE INFLUENCE OF THE GROUND ON THE WIND IS REDUCED, ALLOWABLE SIGN PANEL AREAS MUST BE REDUCED (AS MUCH AS 40%) ACCORDING TO THE AASHTO "STANDARD SPECIFICATIONS FOR STRUCTURAL SUPPORTS FOR HIGHWAY SIGNS, LUMINAIRES AND TRAFFIC SIGNALS", UNDER THE SECTION "LOADS".
 USE AN INCREASED WIND PRESSURE FOR SIGN PANEL CENTROID HEIGHTS 29.0 FT OR MORE ABOVE THE SURROUNDING TERRAIN, AS FOLLOWS:
 ZONE A (REGIONS 1,2,6,8 AND 9): 20.4 PSF
 ZONE B (REGIONS 3,4,5,7,10 AND 11): 27.6 PSF

THESE DETAILS ARE SKETCH DRAWINGS AND ARE NOT TO SCALE
 DIMENSIONS ARE IN INCHES UNLESS OTHERWISE NOTED

 <p>STATE OF NEW YORK DEPARTMENT OF TRANSPORTATION</p>	
<p>MATERIALS DETAILS FOR TYPE A SIGN SUPPORTS</p>	
<p>NUCOR STEEL, MARION INC. U CHANNEL SIGN SUPPORTS STANDARD CAPACITY</p>	
<p>SHEET 3 OF 4</p>	
<p>ISSUED UNDER EB 06-021 EFFECTIVE: 05/02/2006 REVISION:</p>	<p>MD645E-MRB-03</p>

FILE NAME = IP_PWP\dms61672\MARION.E.STD1.SHEET3.DGN
 DATE/TIME = 05-MAY-2006 14:21
 USER = ofr-ank

Group #37829 IFB #23055 - Attachment 08: Nucor Steel, Marion Inc.

70 MPH WIND SPEED

DOUBLE POST

TRIPLE POST

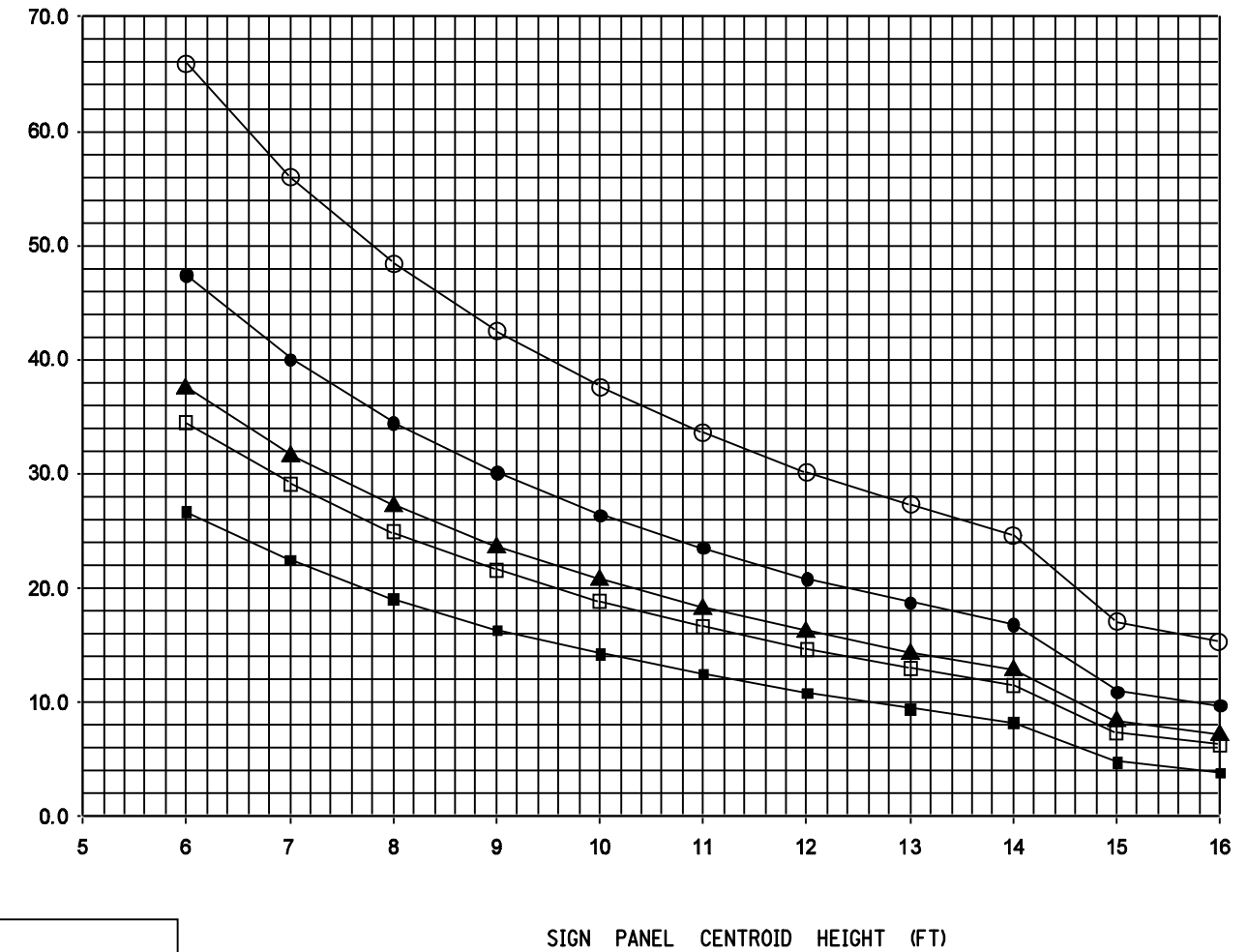
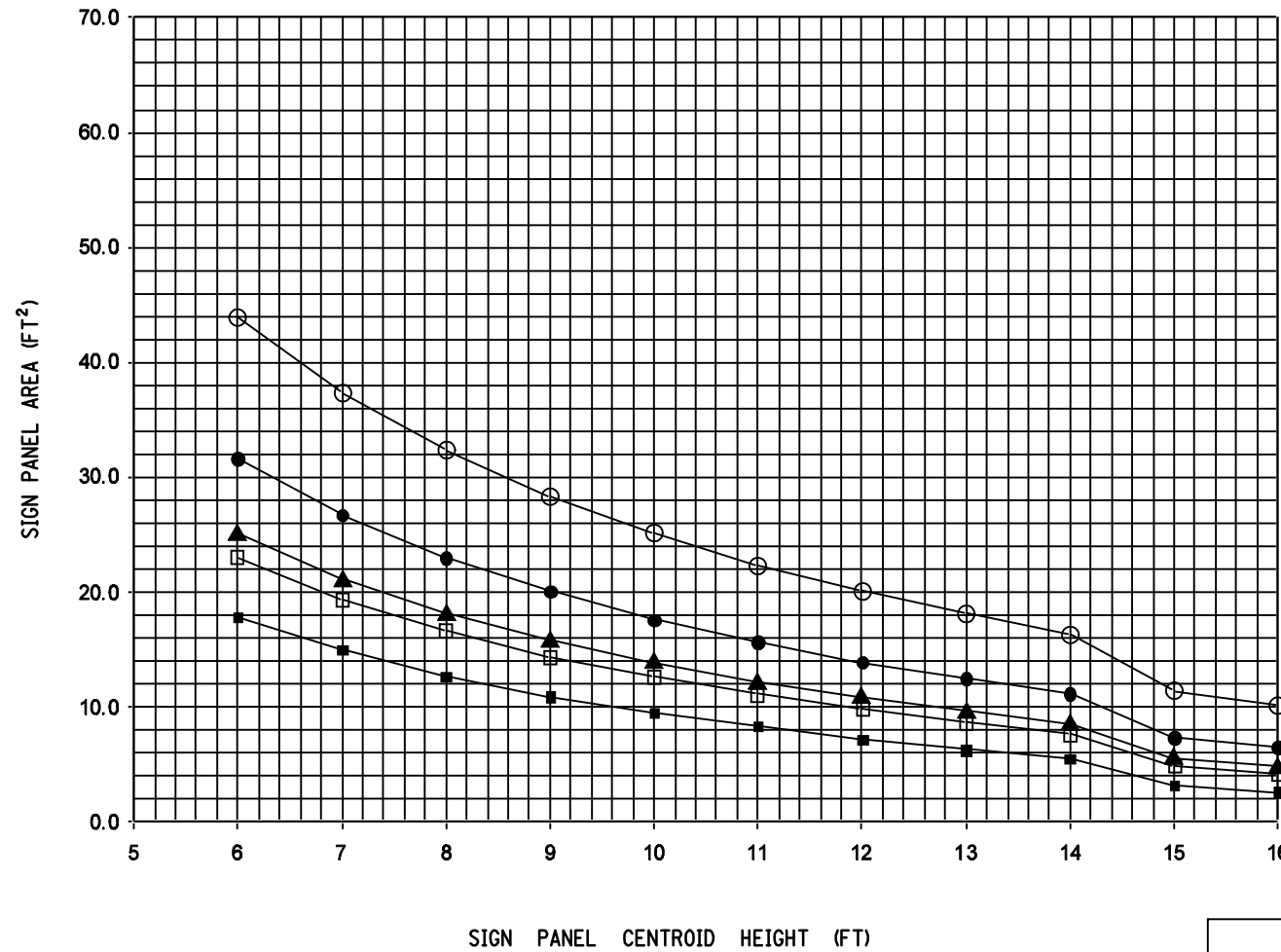

- 4.00 LB/FT POST
- 3.00 LB/FT POST
- ▲ 2.75 LB/FT POST
- 2.50 LB/FT POST
- 2.00 LB/FT POST

CAUTION : ALLOWABLE SIGN PANEL AREAS ARE CALCULATED ASSUMING SITE ELEVATIONS CLOSE TO THE SURROUNDING TERRAIN.
 FOR ELEVATED SITE CONDITIONS (E.G. OVERPASSES, HIGH CONTOUR AREAS) WHERE THE INFLUENCE OF THE GROUND ON THE WIND IS REDUCED, ALLOWABLE SIGN PANEL AREAS MUST BE REDUCED (AS MUCH AS 40%) ACCORDING TO THE AASHTO "STANDARD SPECIFICATIONS FOR STRUCTURAL SUPPORTS FOR HIGHWAY SIGNS, LUMINAIRES AND TRAFFIC SIGNALS", UNDER THE SECTION "LOADS".
 USE AN INCREASED WIND PRESSURE FOR SIGN PANEL CENTROID HEIGHTS 29.0 FT OR MORE ABOVE THE SURROUNDING TERRAIN, AS FOLLOWS:
 ZONE A (REGIONS 1,2,6,8 AND 9): 20.4 PSF
 ZONE B (REGIONS 3,4,5,7,10 AND 11): 27.6 PSF

THESE DETAILS ARE SKETCH DRAWINGS AND ARE NOT TO SCALE
 DIMENSIONS ARE IN INCHES UNLESS OTHERWISE NOTED

 <p>STATE OF NEW YORK DEPARTMENT OF TRANSPORTATION</p>	
<p>MATERIALS DETAILS FOR TYPE A SIGN SUPPORTS</p>	
<p>NUCOR STEEL, MARION INC. U CHANNEL SIGN SUPPORTS STANDARD CAPACITY</p>	
<p>SHEET 4 OF 4</p>	
<p>ISSUED UNDER EB 06-021 EFFECTIVE: 05/02/2006 REVISION:</p>	<p>MD645E-MRB-04</p>

FILE NAME = IP:\PWP\dms61672\MARION.E.STD1.SHEET4.DGN
 DATE/TIME = 05-MAY-2006 14:21
 USER = ofr-ank